



**常州市佳博机械制造有限公司**

电 话: 0086-519-86133523  
传 真: 0086-519-86135153  
地 址: 常州武进前黄运村农场村  
邮 箱: bikemotor@czjbmotor.com  
网 址: <http://www.czjb.com>

**Changzhou JiaBo Machinery Manufacturing Co.,Ltd.**

Tel:0086-519-86511997  
Fax:0086-519-86135153  
E-mail:bikemotor@czjbmotor.com  
Add:Nongchang,Yuncun vill,Qianhuang Town,  
Wujin Dist,Changzhou City  
Web:<http://www.czjb.com>  
<http://www.jiabo-motor.com>

**Technical Service Center in Eastern US**

Contact :Pushkar Phatak  
Tel: 6176788762  
E-mail: Pushkar@wattwagons.com  
Address: 966 Watertown Street, Newton, MA 02465, US

**Technical Service Center in Western US**

Contact :Dexin Li  
Tel: 9494194973  
E-mail:534393576@qq.com  
Address:12 clocktower Irvine,CA 92620

**佳博电机**  
**CZJB MOTOR**

**2022**

# 企业简介

COMPANY PROFILE



Changzhou Jiabo Machinery Manufacturing Co., Ltd. was established in 2008 as a high-tech company integrating product development, production and sales.

The company mainly produces electric bicycle hub motors, mid-drive motors, and torque sensor. We also supply electric bike conversion kit include controller, display, throttle, brake lever, pas and waterproof connected cables.

Our company has experienced product development designers who can develop customized motor products with special requirements in response to the different needs of customers.

Based on the principle of customer consideration and environmental protection, the company uses good raw materials and exquisite production technology to create stable, efficient and durable products for customers.

The factory covers an area of more than 10,000 square meters and has an annual production capacity of 800,000 units. The products have passed CCC, CE, ROHS, EMC, SGS, UKCA, and many other international certifications. We have established a complete quality assurance system and passed the ISO9001 quality system certification.

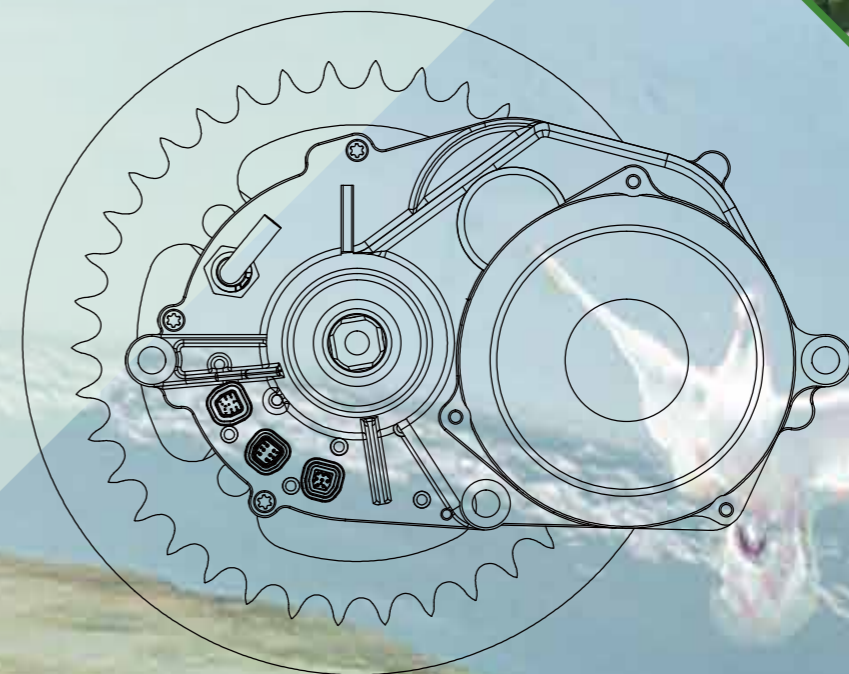



中置电机 Mid drive motor 250W-750W

|        |       |    |
|--------|-------|----|
| MM02   | ----- | 01 |
| MM02-1 | ----- | 02 |
| MM600  | ----- | 03 |



外转子电机 Outer runner motor 350W-500W

|       |       |    |
|-------|-------|----|
| 105CQ | ----- | 18 |
| 105C  | ----- | 19 |
| 105CZ | ----- | 20 |
| 105C2 | ----- | 21 |

内转子电机 Inner rotor motor 250W-350W

|         |       |    |
|---------|-------|----|
| IH53H01 | ----- | 04 |
| IH53H02 | ----- | 05 |



外转子电机 Outer runner motor 350W-500W

|       |       |    |
|-------|-------|----|
| 121TQ | ----- | 22 |
| 121T  | ----- | 23 |
| 121T2 | ----- | 24 |



外转子电机 Outer runner motor 250W-350W

|      |       |    |
|------|-------|----|
| 75Q  | ----- | 06 |
| 75A  | ----- | 07 |
| 75T  | ----- | 08 |
| 75T2 | ----- | 09 |



外转子电机 Outer runner motor 750W-1000W

|          |       |    |
|----------|-------|----|
| 110C     | ----- | 25 |
| 121CZ    | ----- | 26 |
| 135C     | ----- | 27 |
| 205/35   | ----- | 28 |
| 205/35H2 | ----- | 29 |
| 205/55   | ----- | 30 |



外转子电机 Outer runner motor 250W-350W

|      |       |    |
|------|-------|----|
| 90TQ | ----- | 10 |
| 90T  | ----- | 11 |
| 90TZ | ----- | 12 |
| 90T2 | ----- | 13 |



一体轮电机 Wheel hub motor

|         |       |    |
|---------|-------|----|
| 75/12"  | ----- | 31 |
| 90/12"  | ----- | 32 |
| 104/16" | ----- | 33 |
| 104/20" | ----- | 34 |



外转子电机 Outer runner motor 250W-350W

|      |       |    |
|------|-------|----|
| 90Q  | ----- | 14 |
| 90C  | ----- | 15 |
| 90A3 | ----- | 16 |
| 90C2 | ----- | 17 |



电机套件 E-bike kit

|                            |       |    |
|----------------------------|-------|----|
| 电机套件 E-bike kit 250W-1000W | ----- | 35 |
| 中轴力矩 Torque sensor         | ----- | 36 |



# Mid drive system **MM02**

smooth, power saving, easy installation



**mid motor**  
250w-500w, 25-40km/h  
weight 3.6kg  
max torque 110Nm



**display**  
LCD display  
anti reflective  
backlight at night



**battery**  
intube  
long mileage

# Mid drive system **M600**

city style, light weight, good performance



**mid motor**  
250w, 25km/h  
weight 3kg  
max torque 80Nm



**display**  
Color LCD display  
comfortable  
easy to operate



**battery**  
intube  
long mileage

## Rear drive system FOR CITY/MTB E-BIKE

low noise, comfortable, strong



motor

250W-1000W  
front/rear thread/cassette  
weight 3-4kg  
max torque 40-95Nm



display

simple  
popular  
easy to operate



battery

down tube  
lithium battery

## Rear drive system FOR FAT E-BIKE

sports, powerful, load more



motor

750W-1000W  
weight 4-5kg  
max torque 55-100Nm



display

color screen  
USB charge port  
multi-function



battery

rear rack  
lithium battery

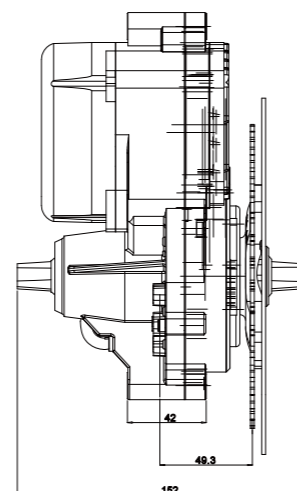
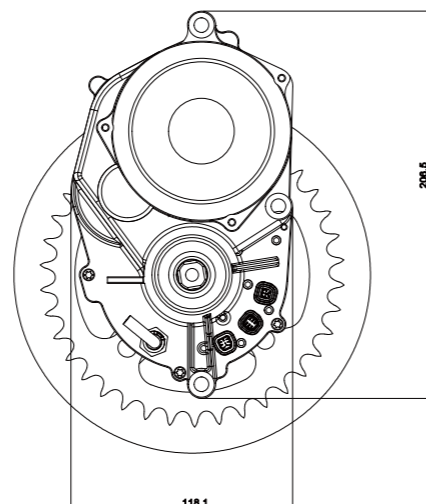

|                        |                     |                                   |        |
|------------------------|---------------------|-----------------------------------|--------|
| Rated Voltage (V) 额定电压 | 36/48               | Operating Temperature (°C) 工作温度   | -20-45 |
| Rated Power (W) 额定功率   | 350-500             | Efficiency (%) 效率                 | ≥82    |
| Weight (Kg) 重量         | 3.6                 | Color颜色                           | Black  |
| Reduction Ratio 减速比    | 1:30                | Noise Grade (dB) 噪音等级             | ≤55db  |
| Torque (N.m) 最大扭矩      | 110                 | IP Grade 防水等级                     | IP65   |
| Rated Speed (RPM) 额定转速 | 80-100              | Salt spray Test Standard (h) 盐雾测试 | 24/96  |
| Sensor 传感器             | Speed&torque sensor |                                   |        |

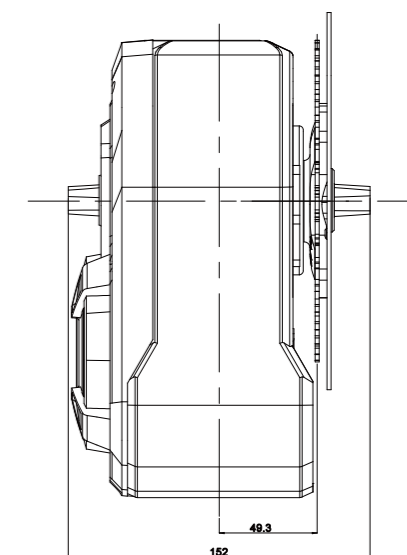
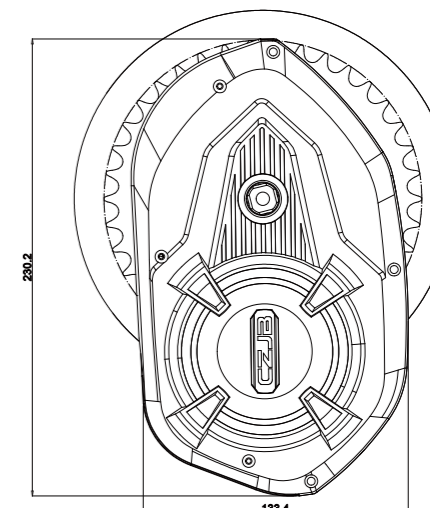

|                        |                     |                                   |        |
|------------------------|---------------------|-----------------------------------|--------|
| Rated Voltage (V) 额定电压 | 36/48               | Operating Temperature (°C) 工作温度   | -20-45 |
| Rated Power (W) 额定功率   | 500-750             | Efficiency (%) 效率                 | ≥82    |
| Weight (Kg) 重量         | 3.6                 | Color颜色                           | Black  |
| Reduction Ratio 减速比    | 1:30                | Noise Grade (dB) 噪音等级             | ≤55db  |
| Torque (N.m) 最大扭矩      | 110                 | IP Grade 防水等级                     | IP65   |
| Rated Speed (RPM) 额定转速 | 80-100              | Salt spray Test Standard (h) 盐雾测试 | 24/96  |
| Sensor 传感器             | Speed&torque sensor |                                   |        |



# mid drive motor

# M600

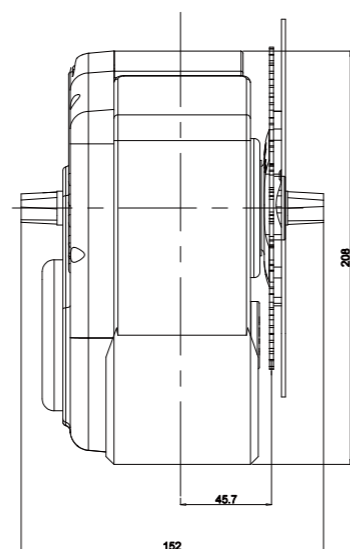
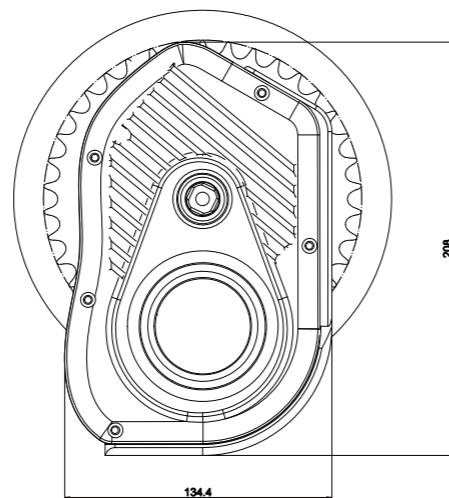

|                        |                     |                                   |        |
|------------------------|---------------------|-----------------------------------|--------|
| Rated Voltage (V) 额定电压 | 36/48               | Operating Temperature (C) 工作温度    | -20-45 |
| Rated Power (W) 额定功率   | 250-350             | Efficiency (%) 效率                 | ≥82    |
| Weight (Kg) 重量         | 3                   | Color颜色                           | Black  |
| Reduction Ratio减速比     | 1:22                | Noise Grade (dB) 噪音等级             | ≤55db  |
| Torque (N.m) 最大扭矩      | 80                  | IP Grade 防水等级                     | IP65   |
| Rated Speed (RPM) 额定转速 | 80-100              | Salt spray Test Standard (h) 盐雾测试 | 24/96  |
| Sensor传感器              | Speed&torque sensor |                                   |        |



# 250w gear motor

# IH53H01

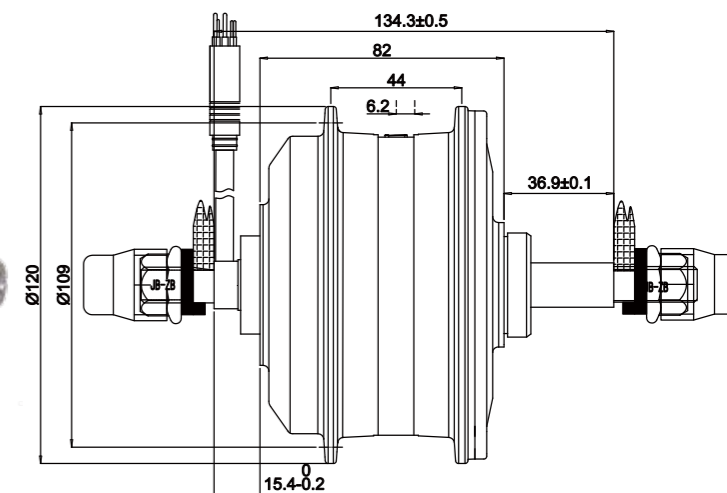

|                          |             |                                   |                      |
|--------------------------|-------------|-----------------------------------|----------------------|
| Position 安装位置            | Rear        | Dropout(mm)开档                     | 135                  |
| Construction电机结构         | Gear        | Brake Type 刹车类型                   | V/Disc brake         |
| Rated Voltage (V) 额定电压   | 24/36/48    | Operating Temperature (C) 工作温度    | -20-45               |
| Rated Power (W) 额定功率     | 250         | Efficiency (%) 效率                 | ≥82                  |
| Weight (Kg) 重量           | 3           | Color颜色                           | Black/Shining/Silver |
| Reduction Ratio减速比       | 1: 13       | Cable Location出线方式                | Shaft side left      |
| Max Torque (N.m) 最大扭矩    | 40          | Noise Grade (dB) 噪音等级             | ≤55db                |
| Wheel Diameter (Inch) 轮径 | 16-28       | IP Grade 防水等级                     | IP65                 |
| Rated Speed (km/h) 额定速度  | 25          | Salt spray Test Standard (h) 盐雾测试 | 24/96                |
| Spoke Specification 辐条   | 36H*12G/13G | Drive and Freewheel飞轮             | 6-7S                 |



250w gear cassette motor

IH53H02

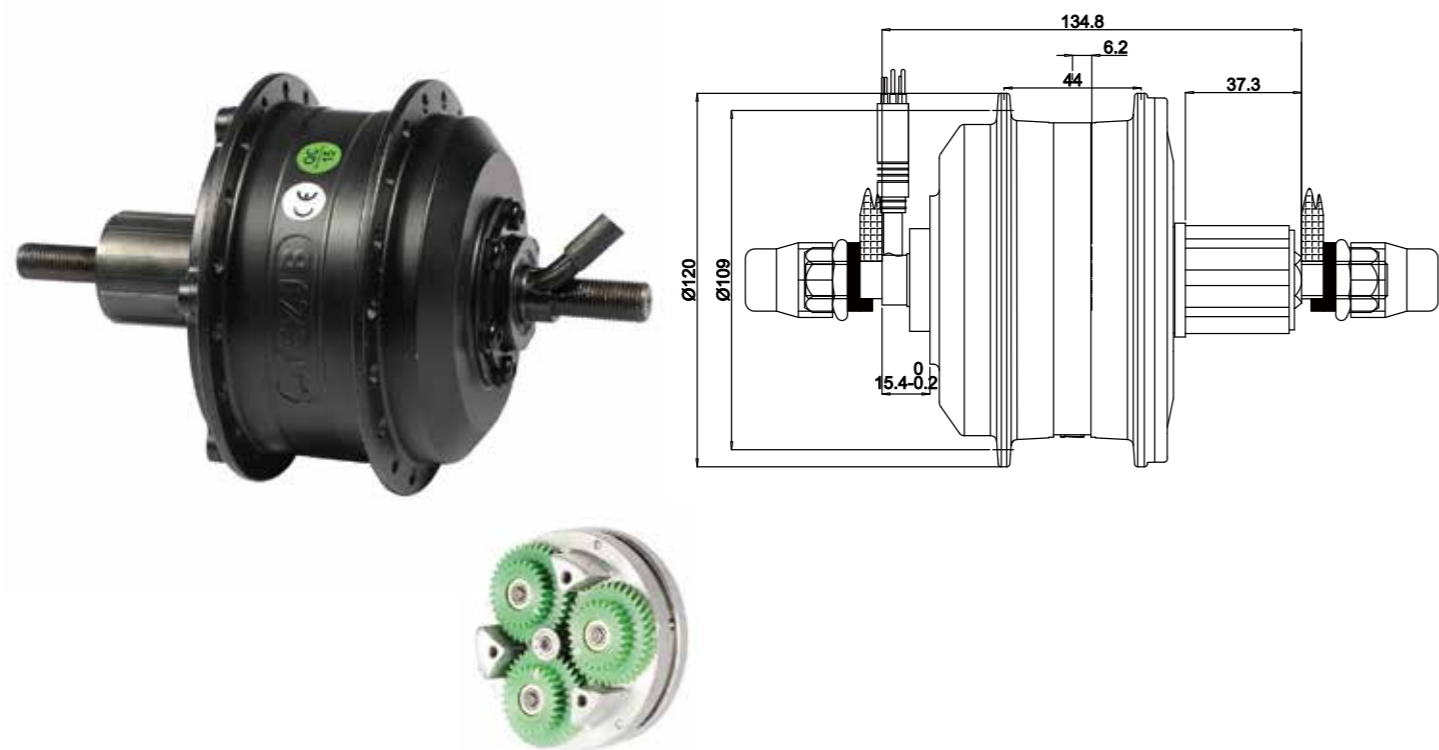

|                          |             |                                   |                      |
|--------------------------|-------------|-----------------------------------|----------------------|
| Position 安装位置            | Rear        | Dropout(mm)开档                     | 138                  |
| Construction电机结构         | Gear        | Brake Type 刹车类型                   | V/Disc brake         |
| Rated Voltage (V) 额定电压   | 24/36/48    | Operating Temperature (°C) 工作温度   | -20-45               |
| Rated Power (W) 额定功率     | 250         | Efficiency (%) 效率                 | ≥82                  |
| Weight (Kg) 重量           | 3           | Color颜色                           | Black/Shining/Silver |
| Reduction Ratio减速比       | 1: 13       | Cable Location出线方式                | Shaft side left      |
| Max Torque (N.m) 最大扭矩    | 40          | Noise Grade (dB) 噪音等级             | ≤55db                |
| Wheel Diameter (Inch) 轮径 | 16-28       | IP Grade 防水等级                     | IP65                 |
| Rated Speed (km/h) 额定速度  | 25          | Salt spray Test Standard (h) 盐雾测试 | 24/96                |
| Spoke Specification 辐条   | 36H*12G/13G | Drive and Freewheel飞轮             | 8-9S                 |

250w light weight front motor

75Q

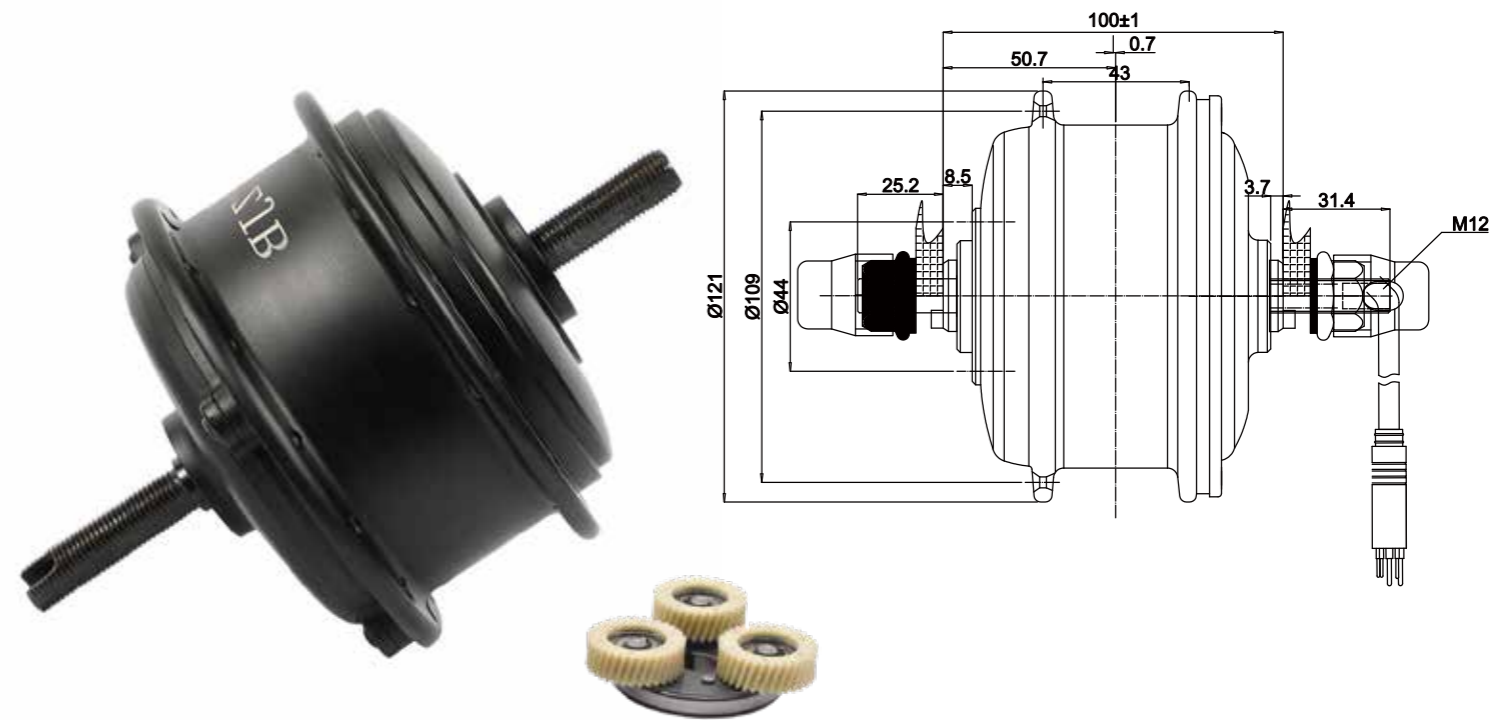

|                          |             |                                   |                      |
|--------------------------|-------------|-----------------------------------|----------------------|
| Position 安装位置            | Front       | Dropout(mm)开档                     | 100                  |
| Construction电机结构         | Gear        | Brake Type 刹车类型                   | V/Disc brake         |
| Rated Voltage (V) 额定电压   | 24/36/48    | Operating Temperature (°C) 工作温度   | -20-45               |
| Rated Power (W) 额定功率     | 180-250     | Efficiency (%) 效率                 | ≥82                  |
| Weight (Kg) 重量           | 1.9         | Color颜色                           | Black/Shining/Silver |
| Reduction Ratio减速比       | 1:4.35      | Cable Location出线方式                | Shaft center right   |
| Max Torque (N.m) 最大扭矩    | 35          | Noise Grade (dB) 噪音等级             | ≤55db                |
| Wheel Diameter (Inch) 轮径 | 16-28       | IP Grade 防水等级                     | IP65                 |
| Rated Speed (km/h) 额定速度  | 25          | Salt spray Test Standard (h) 盐雾测试 | 24/96                |
| Spoke Specification 辐条   | 36H*12G/13G | Drive and Freewheel飞轮             | /                    |



☆☆ 250w gear motor

75A

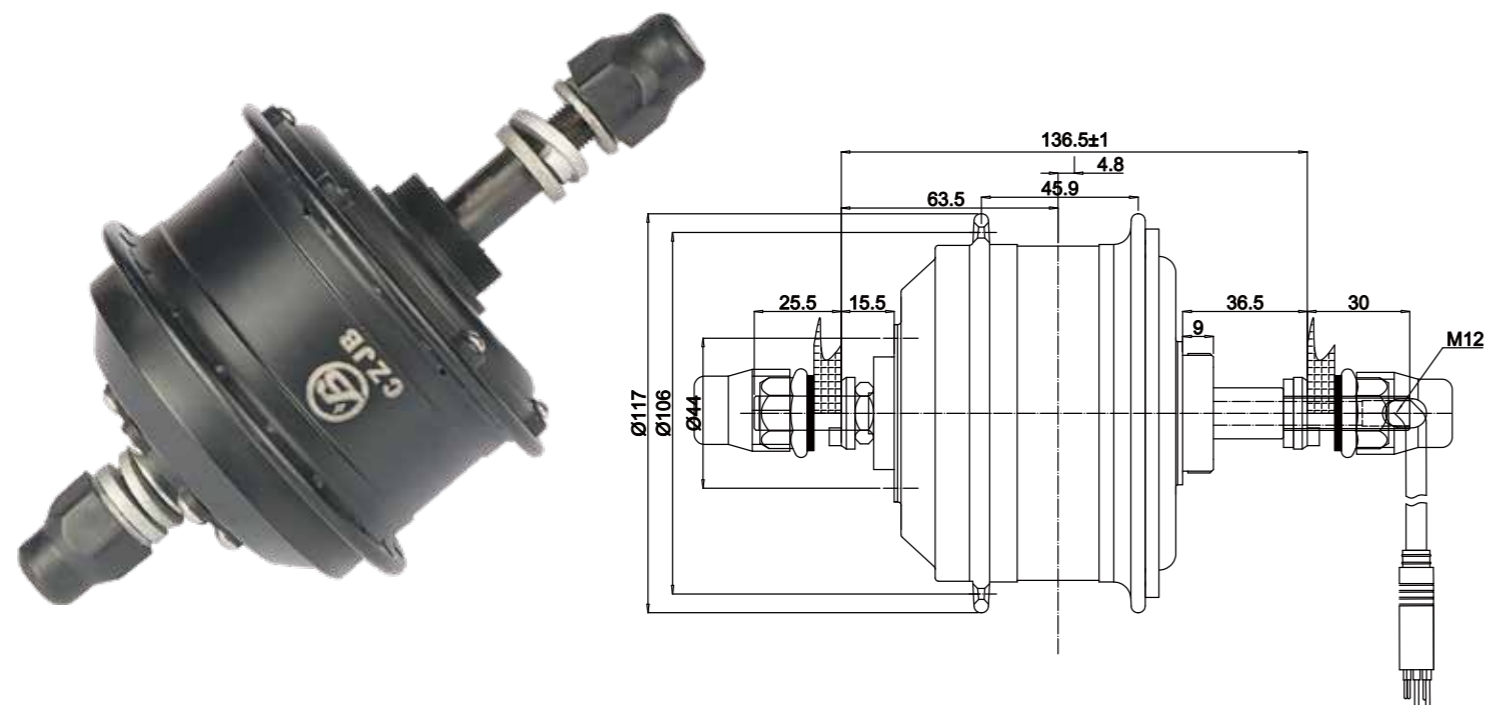

|                          |             |                                   |                    |
|--------------------------|-------------|-----------------------------------|--------------------|
| Position 安装位置            | Rear        | Dropout(mm)开档                     | 135                |
| Construction电机结构         | Gear        | Brake Type 刹车类型                   | V/Disc brake       |
| Rated Voltage (V) 额定电压   | 24/36/48    | Operating Temperature (C) 工作温度    | -20-45             |
| Rated Power (W) 额定功率     | 180-250     | Efficiency (%) 效率                 | ≥82                |
| Weight (Kg) 重量           | 1.9         | Color颜色                           | Black/Silver       |
| Reduction Ratio减速比       | 1:4.4       | Cable Location出线方式                | Shaft center right |
| Max Torque (N.m) 最大扭矩    | 35          | Noise Grade (dB) 噪音等级             | ≤55db              |
| Wheel Diameter (Inch) 轮径 | 16-28       | IP Grade 防水等级                     | IP65               |
| Rated Speed (km/h) 额定速度  | 25          | Salt spray Test Standard (h) 盐雾测试 | 24/96              |
| Spoke Specification辐条    | 36H*12G/13G | Drive and Freewheel飞轮             | 6-7S               |

☆☆ 250w light weight gear motor

75T

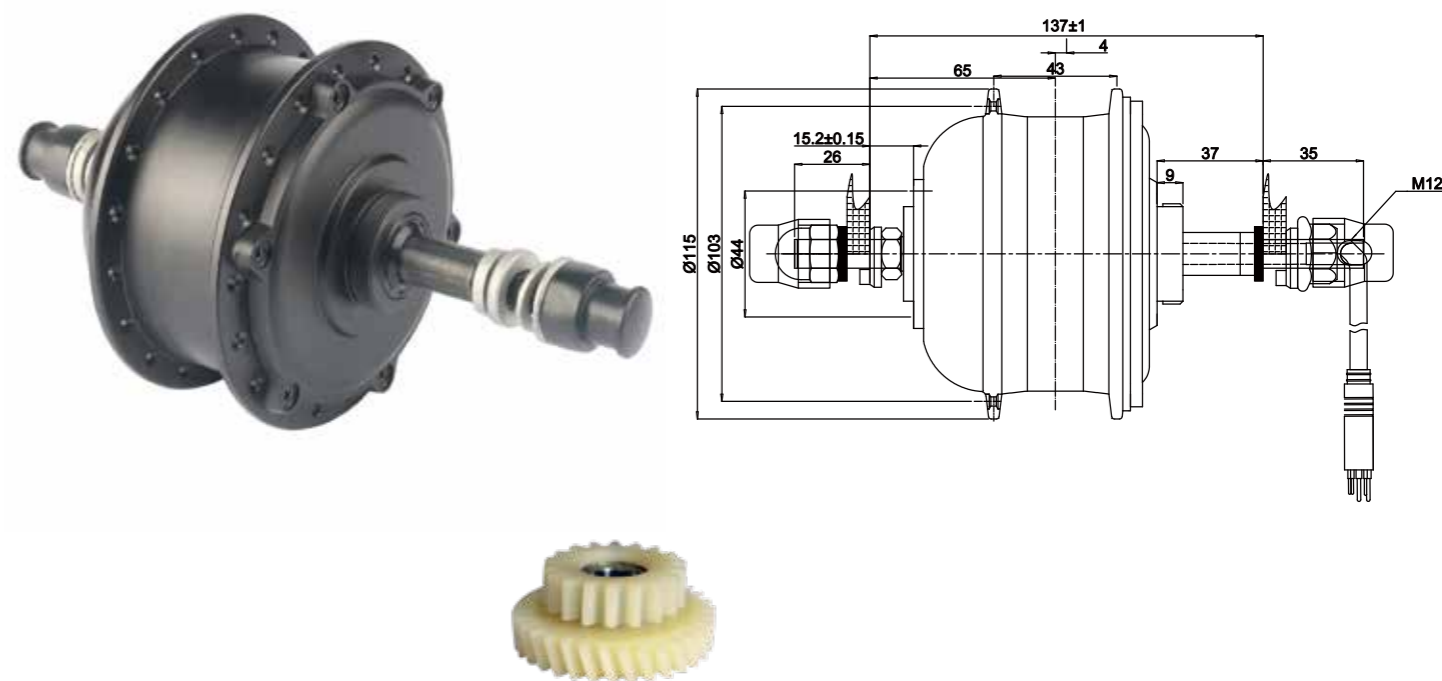

|                          |             |                                   |                      |
|--------------------------|-------------|-----------------------------------|----------------------|
| Position 安装位置            | Rear        | Dropout(mm)开档                     | 137                  |
| Construction电机结构         | Gear        | Brake Type 刹车类型                   | V/Disc brake         |
| Rated Voltage (V) 额定电压   | 24/36/48    | Operating Temperature (C) 工作温度    | -20-45               |
| Rated Power (W) 额定功率     | 180-320     | Efficiency (%) 效率                 | ≥82                  |
| Weight (Kg) 重量           | 2.2         | Color颜色                           | Black/Shining/Silver |
| Reduction Ratio减速比       | 1:6.1       | Cable Location出线方式                | Shaft center right   |
| Max Torque (N.m) 最大扭矩    | 40          | Noise Grade (dB) 噪音等级             | ≤55db                |
| Wheel Diameter (Inch) 轮径 | 16-28       | IP Grade 防水等级                     | IP65                 |
| Rated Speed (km/h) 额定速度  | 25          | Salt spray Test Standard (h) 盐雾测试 | 24/96                |
| Spoke Specification辐条    | 36H*12G/13G | Drive and Freewheel飞轮             | 6-7S                 |

☆☆ 250w light weight cassette motor

75T2

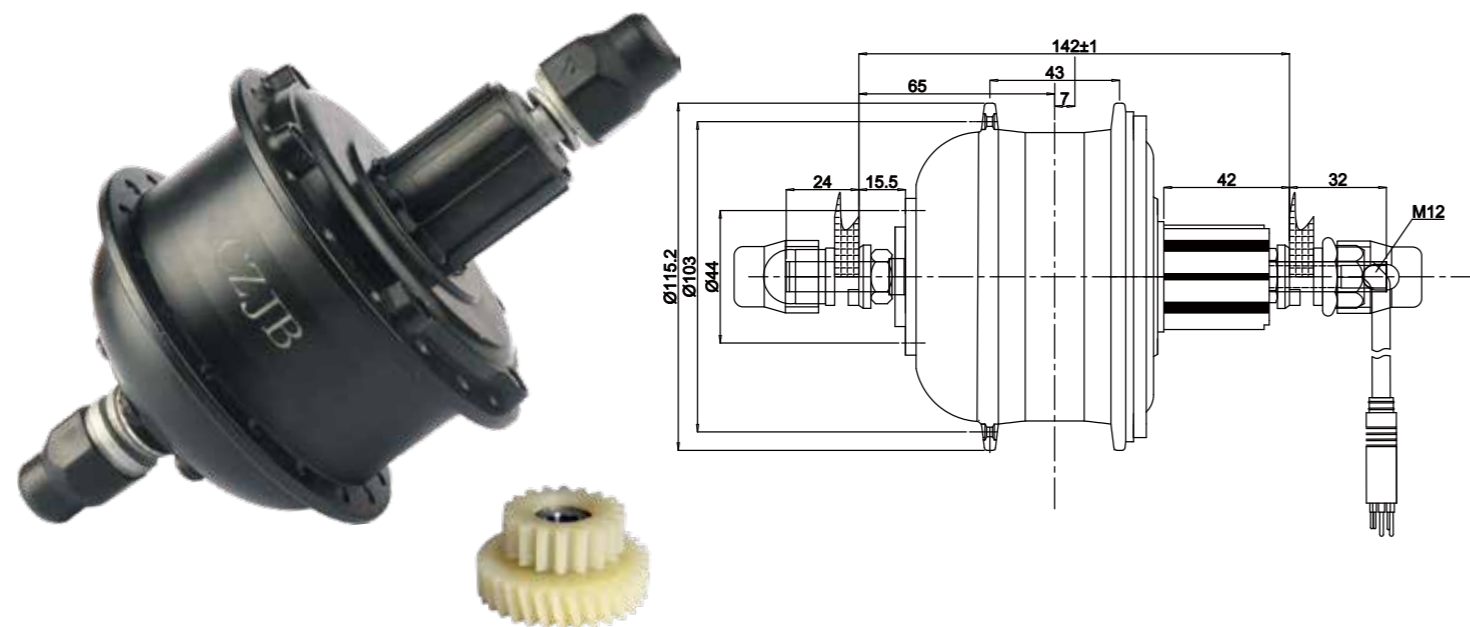

|                          |             |                                   |                      |
|--------------------------|-------------|-----------------------------------|----------------------|
| Position 安装位置            | Rear        | Dropout(mm)开档                     | 142                  |
| Construction电机结构         | Gear        | Brake Type 刹车类型                   | V/Disc brake         |
| Rated Voltage (V) 额定电压   | 24/36/48    | Operating Temperature (°C) 工作温度   | -20-45               |
| Rated Power (W) 额定功率     | 180-320     | Efficiency (%) 效率                 | ≥82                  |
| Weight (Kg) 重量           | 2.2         | Color颜色                           | Black/Shining/Silver |
| Reduction Ratio减速比       | 1:6.1       | Cable Location出线方式                | Shaft center right   |
| Max Torque (N.m) 最大扭矩    | 40          | Noise Grade (dB) 噪音等级             | ≤55db                |
| Wheel Diameter (Inch) 轮径 | 16-28       | IP Grade 防水等级                     | IP65                 |
| Rated Speed (km/h) 额定速度  | 25          | Salt spray Test Standard (h) 盐雾测试 | 24/96                |
| Spoke Specification辐条    | 36H*12G/13G | Drive and Freewheel飞轮             | 8-9S                 |

☆☆ 250-350w gear front motor

90TQ

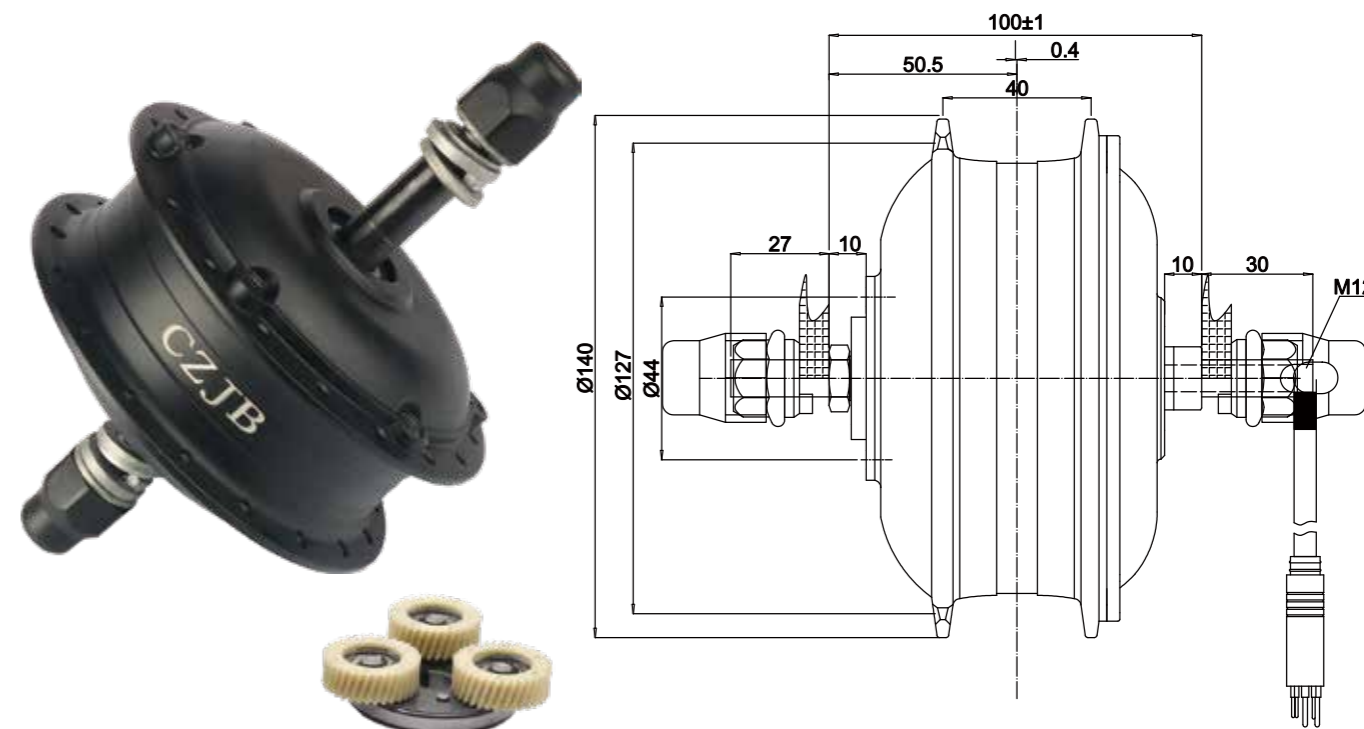

|                          |             |                                   |                       |
|--------------------------|-------------|-----------------------------------|-----------------------|
| Position 安装位置            | Front       | Dropout(mm)开档                     | 100                   |
| Construction电机结构         | Gear        | Brake Type 刹车类型                   | V/Disc brake          |
| Rated Voltage (V) 额定电压   | 24/36/48    | Operating Temperature (°C) 工作温度   | -20-45                |
| Rated Power (W) 额定功率     | 180-350     | Efficiency (%) 效率                 | ≥82                   |
| Weight (Kg) 重量           | 2.8         | Color颜色                           | Black//Shining/Silver |
| Reduction Ratio减速比       | 1:5.2       | Cable Location出线方式                | Shaft side right      |
| Max Torque (N.m) 最大扭矩    | 40          | Noise Grade (dB) 噪音等级             | ≤55db                 |
| Wheel Diameter (Inch) 轮径 | 16-28       | IP Grade 防水等级                     | IP65                  |
| Rated Speed (km/h) 额定速度  | 25          | Salt spray Test Standard (h) 盐雾测试 | 24/96                 |
| Spoke Specification辐条    | 36H*12G/13G | Drive and Freewheel飞轮             | /                     |

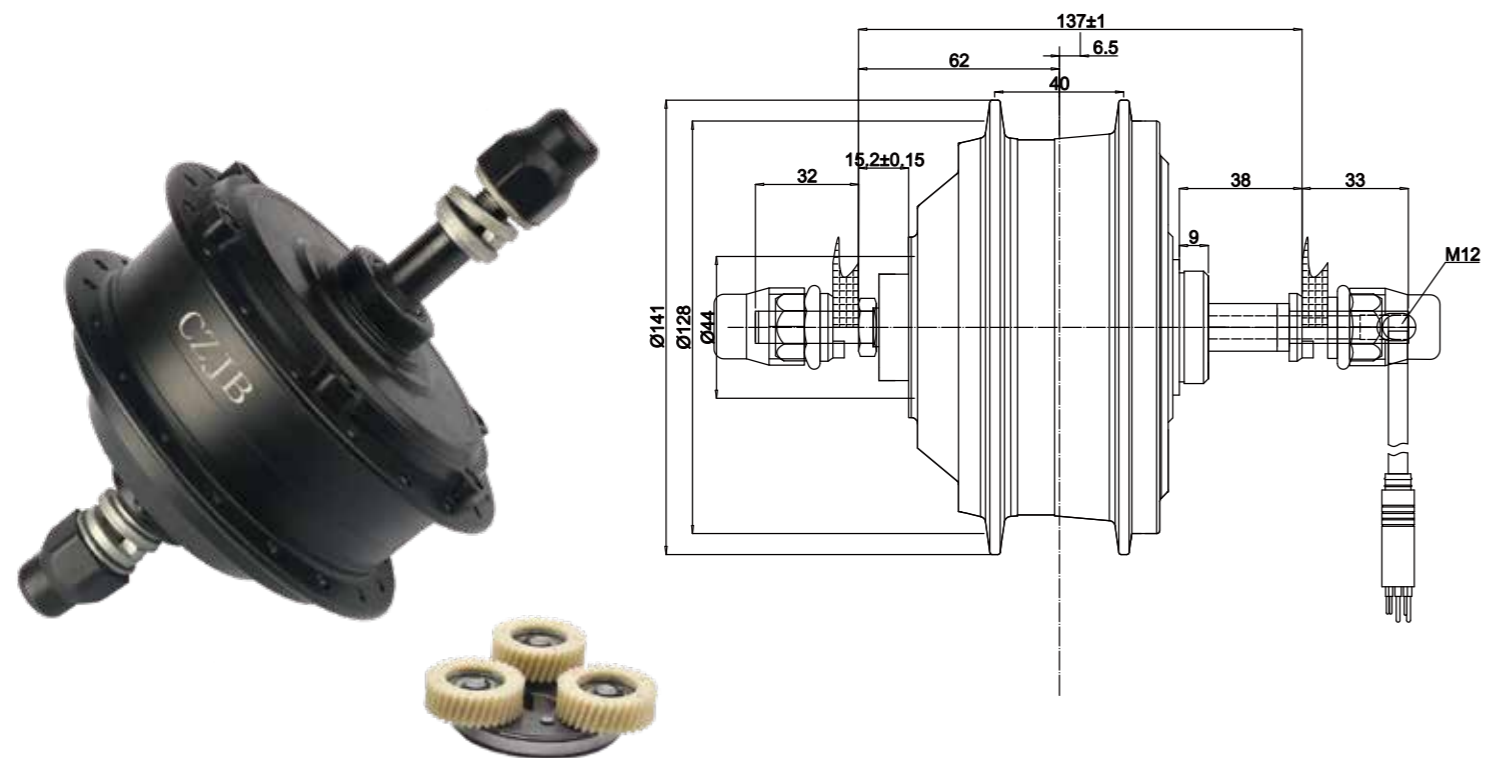

|                          |             |                                   |                      |
|--------------------------|-------------|-----------------------------------|----------------------|
| Position 安装位置            | Rear        | Dropout(mm)开档                     | 137                  |
| Construction电机结构         | Gear        | Brake Type 刹车类型                   | V/Disc brake         |
| Rated Voltage (V) 额定电压   | 24/36/48    | Operating Temperature (C) 工作温度    | -20-45               |
| Rated Power (W) 额定功率     | 180-350     | Efficiency (%) 效率                 | ≥82                  |
| Weight (Kg) 重量           | 3           | Color颜色                           | Black/Shining/Silver |
| Reduction Ratio减速比       | 1:5.2       | Cable Location出线方式                | Shaft center right   |
| Max Torque (N.m) 最大扭矩    | 40          | Noise Grade (dB) 噪音等级             | ≤55db                |
| Wheel Diameter (Inch) 轮径 | 16-28       | IP Grade 防水等级                     | IP65                 |
| Rated Speed (km/h) 额定速度  | 25          | Salt spray Test Standard (h) 盐雾测试 | 24/96                |
| Spoke Specification辐条    | 36H*12G/13G | Drive and Freewheel 飞轮            | 6-7S                 |

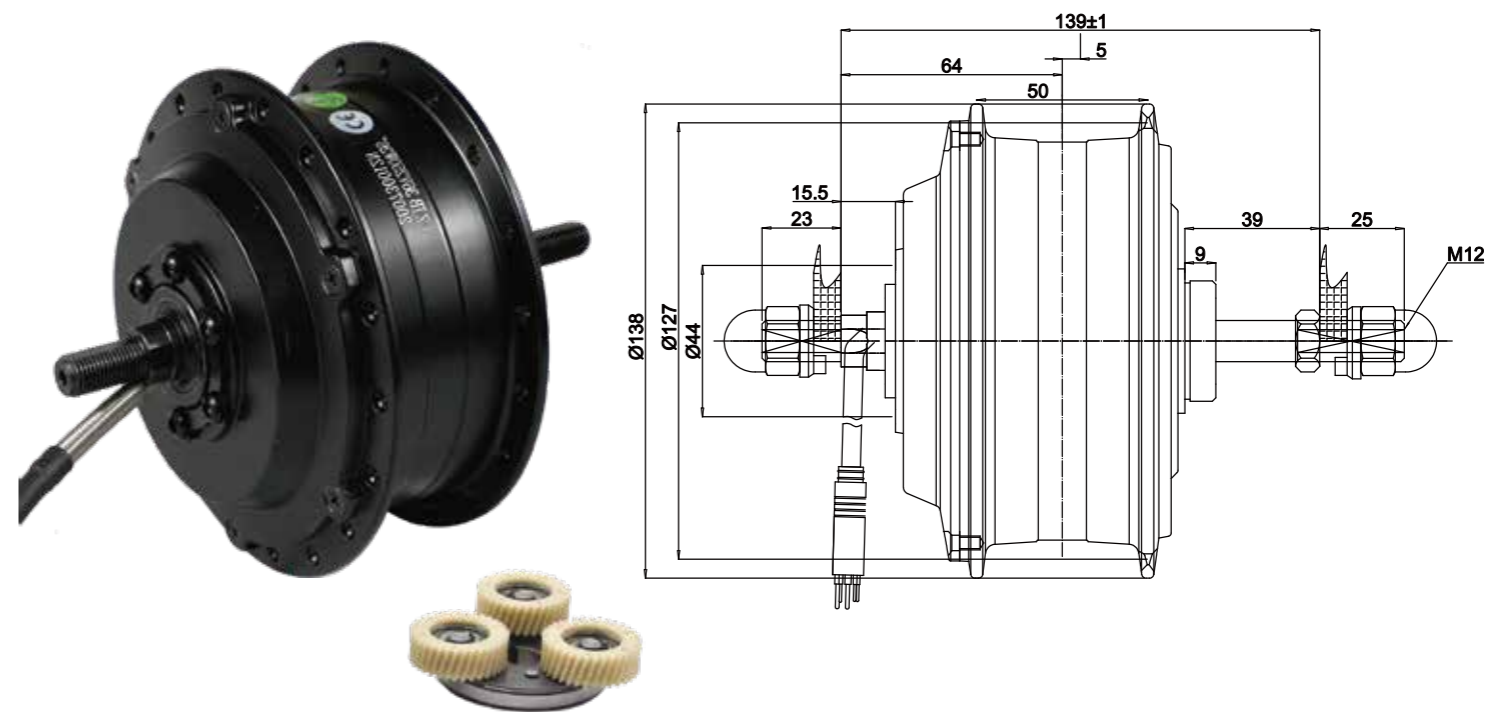

|                          |             |                                   |                      |
|--------------------------|-------------|-----------------------------------|----------------------|
| Position 安装位置            | Rear        | Dropout(mm)开档                     | 139                  |
| Construction电机结构         | Gear        | Brake Type 刹车类型                   | V/Disc brake         |
| Rated Voltage (V) 额定电压   | 36/48       | Operating Temperature (C) 工作温度    | -20-45               |
| Rated Power (W) 额定功率     | 250/350     | Efficiency (%) 效率                 | ≥82                  |
| Weight (Kg) 重量           | 3           | Color颜色                           | Black/Shining/Silver |
| Reduction Ratio减速比       | 1: 5.2      | Cable Location出线方式                | Shaft side left      |
| Max Torque (N.m) 最大扭矩    | 40          | Noise Grade (dB) 噪音等级             | ≤55db                |
| Wheel Diameter (Inch) 轮径 | 16-28       | IP Grade 防水等级                     | IP65                 |
| Rated Speed (km/h) 额定速度  | 25          | Salt spray Test Standard (h) 盐雾测试 | 24/96                |
| Spoke Specification 辐条   | 36H*12G/13G | Drive and Freewheel 飞轮            | 6-7S                 |

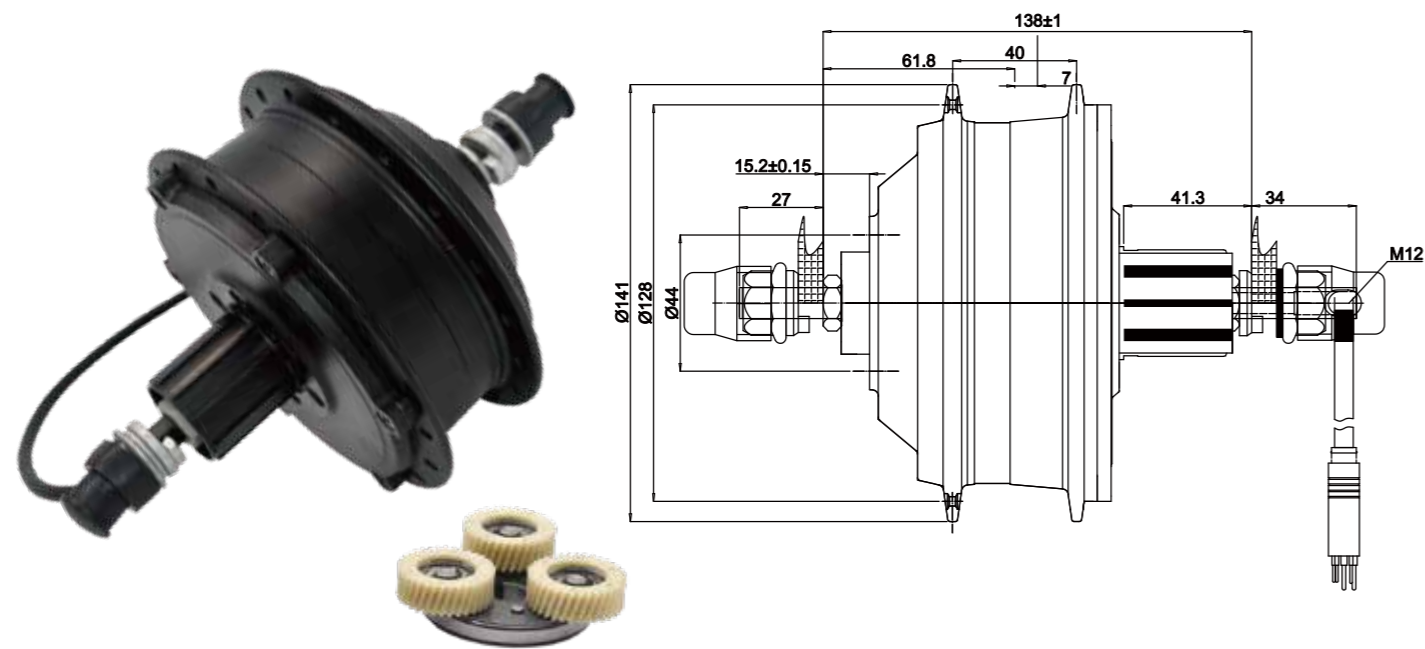

|                          |             |                                   |                      |
|--------------------------|-------------|-----------------------------------|----------------------|
| Position 安装位置            | Rear        | Dropout(mm)开档                     | 138                  |
| Construction电机结构         | Gear        | Brake Type 刹车类型                   | V/Disc brake         |
| Rated Voltage (V) 额定电压   | 24/36/48    | Operating Temperature (°C) 工作温度   | -20-45               |
| Rated Power (W) 额定功率     | 180-350     | Efficiency (%) 效率                 | ≥82                  |
| Weight (Kg) 重量           | 3           | Color颜色                           | Black/Shining/Silver |
| Reduction Ratio减速比       | 1:5.2       | Cable Location出线方式                | Shaft center right   |
| Max Torque (N.m) 最大扭矩    | 40          | Noise Grade (dB) 噪音等级             | ≤55db                |
| Wheel Diameter (Inch) 轮径 | 16-28       | IP Grade 防水等级                     | IP65                 |
| Rated Speed (km/h) 额定速度  | 25          | Salt spray Test Standard (h) 盐雾测试 | 24/96                |
| Spoke Specification辐条    | 36H*12G/13G | Drive and Freewheel 飞轮            | 9S                   |

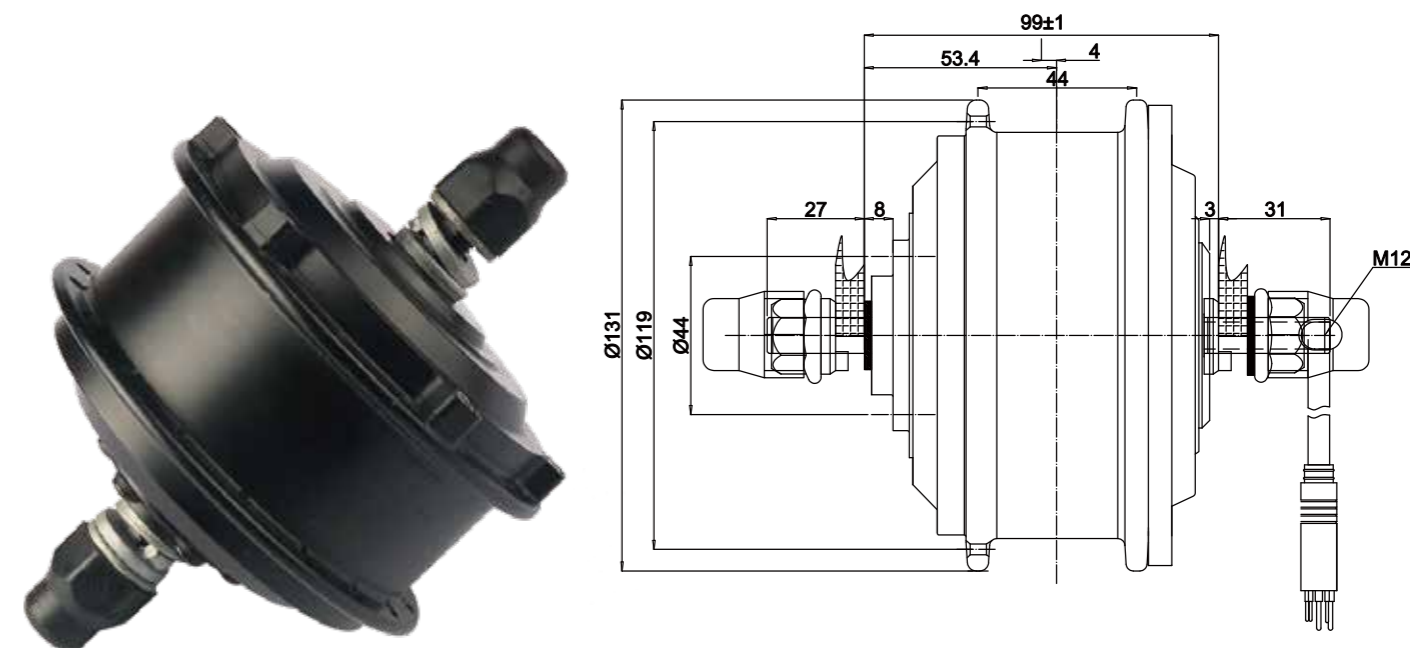

|                          |             |                                   |                       |
|--------------------------|-------------|-----------------------------------|-----------------------|
| Position 安装位置            | Front       | Dropout(mm)开档                     | 100                   |
| Construction电机结构         | Gear        | Brake Type 刹车类型                   | V/Disc brake          |
| Rated Voltage (V) 额定电压   | 24/36/48    | Operating Temperature (°C) 工作温度   | -20-45                |
| Rated Power (W) 额定功率     | 180-350     | Efficiency (%) 效率                 | ≥82                   |
| Weight (Kg) 重量           | 2.8         | Color颜色                           | Black//Shining/Silver |
| Reduction Ratio减速比       | 1:4.4       | Cable Location出线方式                | Shaft center right    |
| Max Torque (N.m) 最大扭矩    | 35          | Noise Grade (dB) 噪音等级             | ≤55db                 |
| Wheel Diameter (Inch) 轮径 | 16-28       | IP Grade 防水等级                     | IP65                  |
| Rated Speed (km/h) 额定速度  | 25          | Salt spray Test Standard (h) 盐雾测试 | 24/96                 |
| Spoke Specification辐条    | 36H*12G/13G | Drive and Freewheel 飞轮            | /                     |

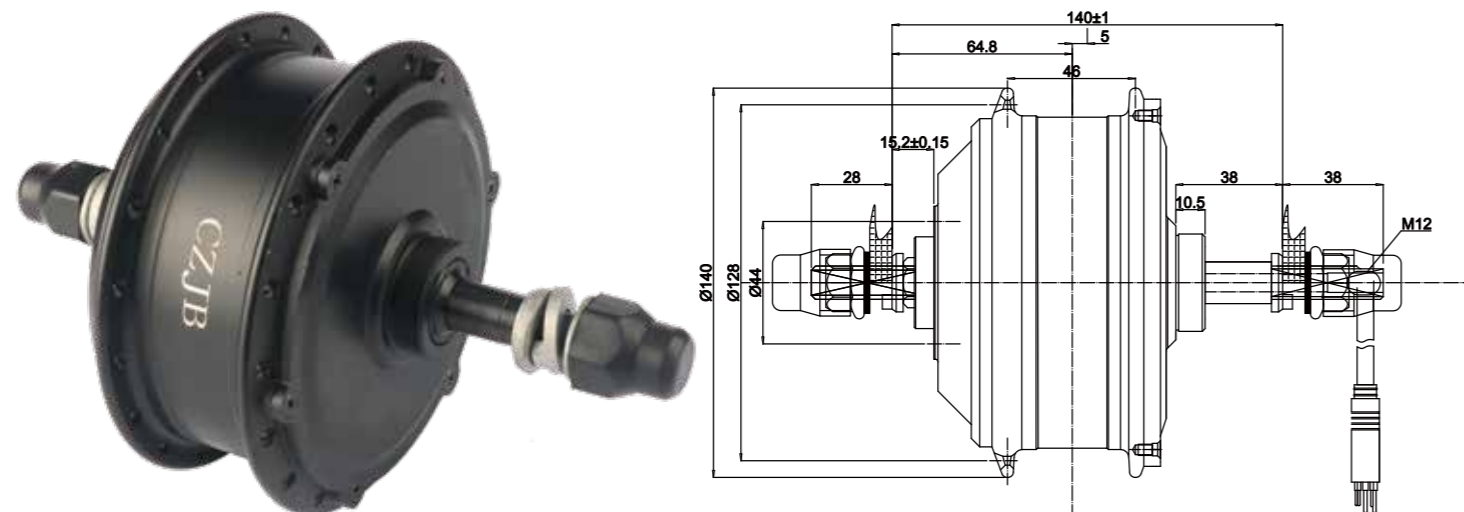

|                          |             |                                   |                       |
|--------------------------|-------------|-----------------------------------|-----------------------|
| Position 安装位置            | Rear        | Dropout(mm)开档                     | 140                   |
| Construction电机结构         | Gear        | Brake Type 刹车类型                   | V/Disc brake          |
| Rated Voltage (V) 额定电压   | 24/36/48    | Operating Temperature (C) 工作温度    | -20-45                |
| Rated Power (W) 额定功率     | 180-350     | Efficiency (%) 效率                 | ≥82                   |
| Weight (Kg) 重量           | 3           | Color颜色                           | Black//Shining/Silver |
| Reduction Ratio减速比       | 1:4.4       | Cable Location出线方式                | Shaft center right    |
| Max Torque (N.m) 最大扭矩    | 35          | Noise Grade (dB) 噪音等级             | ≤55db                 |
| Wheel Diameter (Inch) 轮径 | 16-28       | IP Grade 防水等级                     | IP65                  |
| Rated Speed (km/h) 额定速度  | 25          | Salt spray Test Standard (h) 盐雾测试 | 24/96                 |
| Spoke Specification辐条    | 36H*12G/13G | Drive and Freewheel 飞轮            | 6-7S                  |

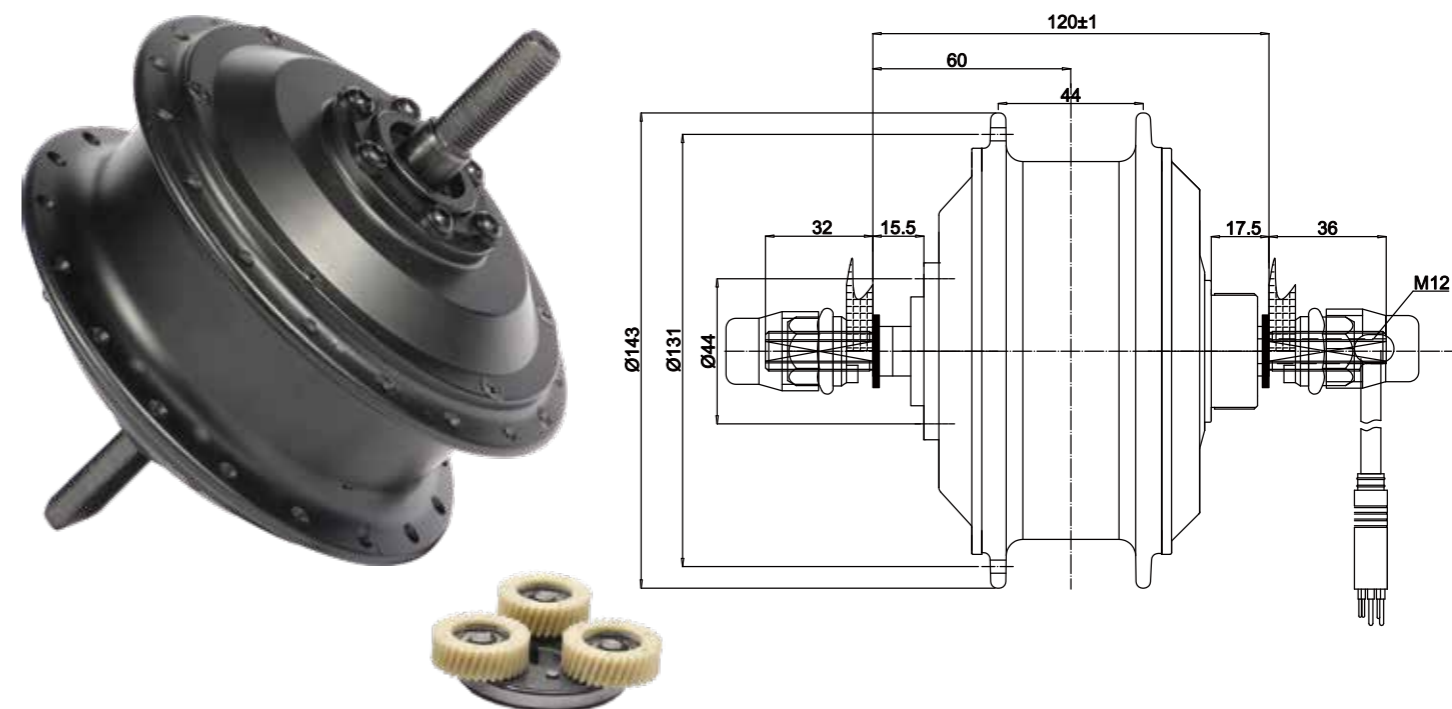

|                          |             |                                   |                              |
|--------------------------|-------------|-----------------------------------|------------------------------|
| Position 安装位置            | Rear        | Dropout(mm)开档                     | 120/126/130                  |
| Construction电机结构         | Gear        | Brake Type 刹车类型                   | V/Disc brake                 |
| Rated Voltage (V) 额定电压   | 24/36/48    | Operating Temperature (C) 工作温度    | -20-45                       |
| Rated Power (W) 额定功率     | 180-350     | Efficiency (%) 效率                 | ≥82                          |
| Weight (Kg) 重量           | 3           | Color颜色                           | Black//Shining/Silver        |
| Reduction Ratio减速比       | 1:4.4       | Cable Location出线方式                | Shaft side/center left/right |
| Max Torque (N.m) 最大扭矩    | 35          | Noise Grade (dB) 噪音等级             | ≤55db                        |
| Wheel Diameter (Inch) 轮径 | 16-28       | IP Grade 防水等级                     | IP65                         |
| Rated Speed (km/h) 额定速度  | 25          | Salt spray Test Standard (h) 盐雾测试 | 24/96                        |
| Spoke Specification辐条    | 36H*12G/13G | Drive and Freewheel 飞轮            | 1S                           |



# 250-350w gear cassette motor

## 90C2

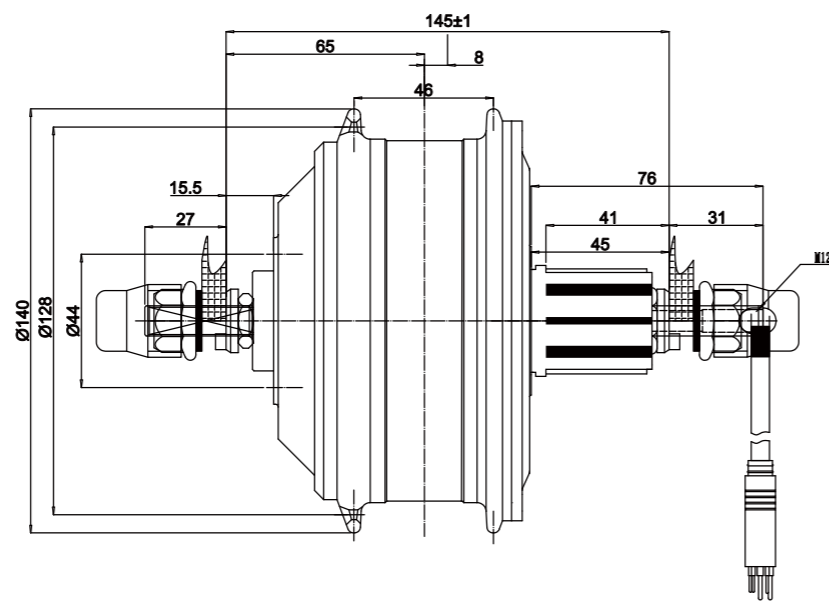

# gear front motor

## 105CQ

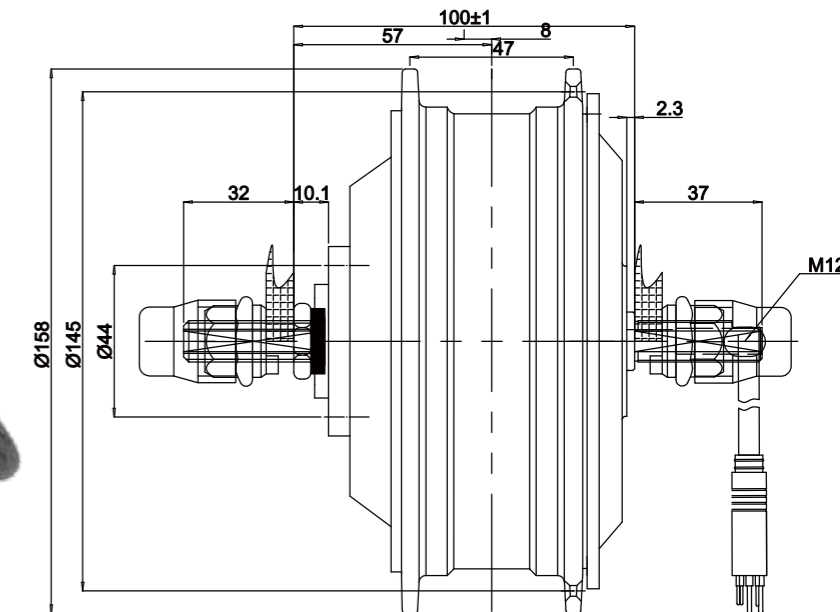

|                          |             |                                   |                       |
|--------------------------|-------------|-----------------------------------|-----------------------|
| Position 安装位置            | Rear        | Dropout(mm)开档                     | 145                   |
| Construction电机结构         | Gear        | Brake Type 刹车类型                   | V/Disc brake          |
| Rated Voltage (V) 额定电压   | 24/36/48    | Operating Temperature (C) 工作温度    | -20-45                |
| Rated Power (W) 额定功率     | 180-350     | Efficiency (%) 效率                 | ≥82                   |
| Weight (Kg) 重量           | 3           | Color颜色                           | Black//Shining/Silver |
| Reduction Ratio减速比       | 1:4.4       | Cable Location出线方式                | Shaft center right    |
| Max Torque (N.m) 最大扭矩    | 35          | Noise Grade (dB) 噪音等级             | ≤55db                 |
| Wheel Diameter (Inch) 轮径 | 16-28       | IP Grade 防水等级                     | IP65                  |
| Rated Speed (km/h) 额定速度  | 25          | Salt spray Test Standard (h) 盐雾测试 | 24/96                 |
| Spoke Specification辐条    | 36H*12G/13G | Drive and Freewheel 飞轮            | 9S                    |

|                          |             |                                   |                      |
|--------------------------|-------------|-----------------------------------|----------------------|
| Position 安装位置            | Front       | Dropout(mm)开档                     | 100                  |
| Construction电机结构         | Gear        | Brake Type 刹车类型                   | V/Disc brake         |
| Rated Voltage (V) 额定电压   | 24/36/48/60 | Operating Temperature (C) 工作温度    | -20-45               |
| Rated Power (W) 额定功率     | 250-500     | Efficiency (%) 效率                 | ≥82                  |
| Weight (Kg) 重量           | 3           | Color颜色                           | Black/Shining/Silver |
| Reduction Ratio减速比       | 1:5/1:5.2   | Cable Location出线方式                | Shaft center right   |
| Max Torque (N.m) 最大扭矩    | 40          | Noise Grade (dB) 噪音等级             | ≤55db                |
| Wheel Diameter (Inch) 轮径 | 16-28       | IP Grade 防水等级                     | IP65                 |
| Rated Speed (km/h) 额定速度  | 25          | Salt spray Test Standard (h) 盐雾测试 | 24/96                |
| Spoke Specification 辐条   | 36H*12G/13G | Drive and Freewheel 飞轮            | /                    |



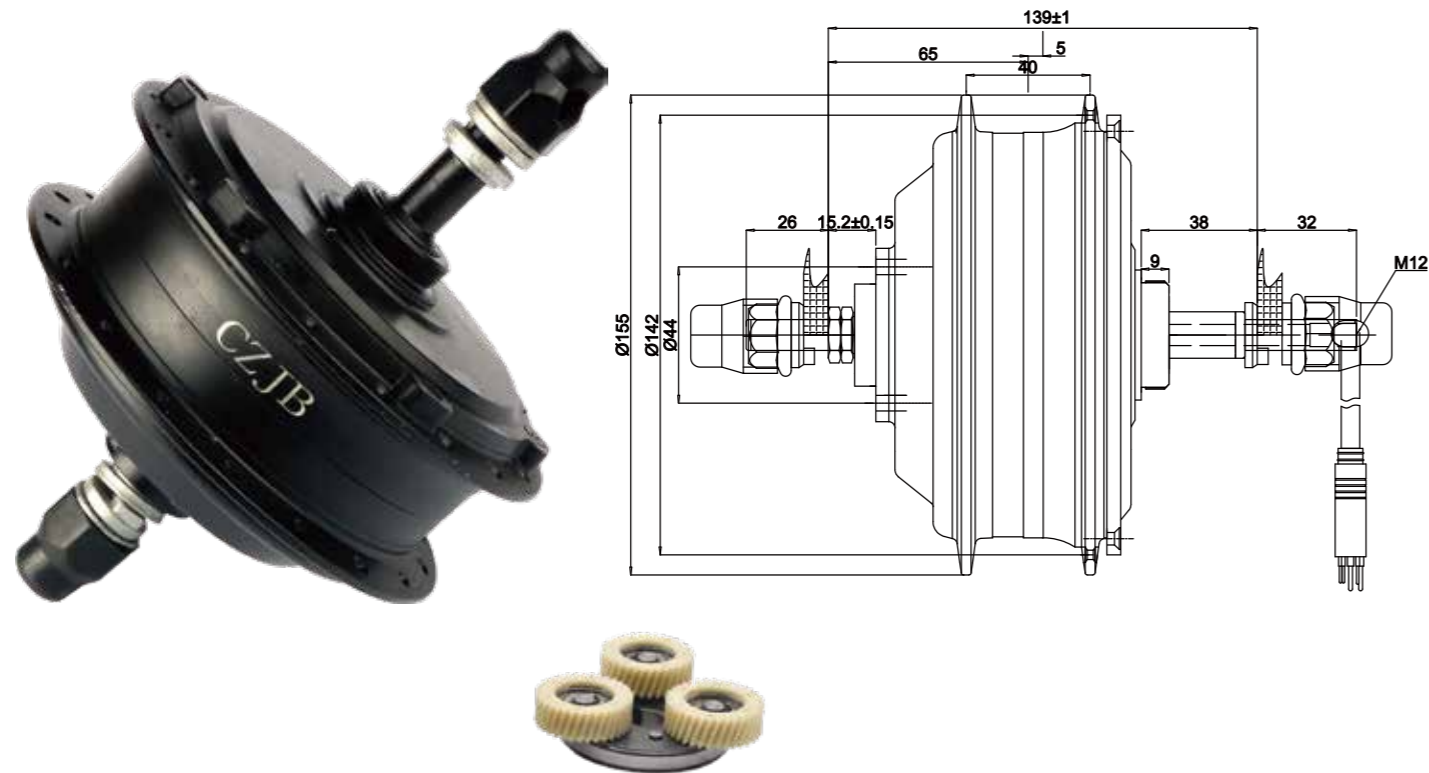

|                          |             |                                   |                      |
|--------------------------|-------------|-----------------------------------|----------------------|
| Position 安装位置            | Rear        | Dropout(mm)开档                     | 139                  |
| Construction电机结构         | Gear        | Brake Type 刹车类型                   | V/Disc brake         |
| Rated Voltage (V) 额定电压   | 24/36/48/60 | Operating Temperature (°C) 工作温度   | -20-45               |
| Rated Power (W) 额定功率     | 250-500     | Efficiency (%) 效率                 | ≥82                  |
| Weight (Kg) 重量           | 3.5         | Color颜色                           | Black/Shining/Silver |
| Reduction Ratio减速比       | 1:5.8       | Cable Location出线方式                | Shaft center right   |
| Max Torque (N.m) 最大扭矩    | 40          | Noise Grade (dB) 噪音等级             | ≤55db                |
| Wheel Diameter (Inch) 轮径 | 16-28       | IP Grade 防水等级                     | IP65                 |
| Rated Speed (km/h) 额定速度  | 25-35       | Salt spray Test Standard (h) 盐雾测试 | 24/96                |
| Spoke Specification 辐条   | 36H*12G/13G | Drive and Freewheel飞轮             | 6-7S                 |

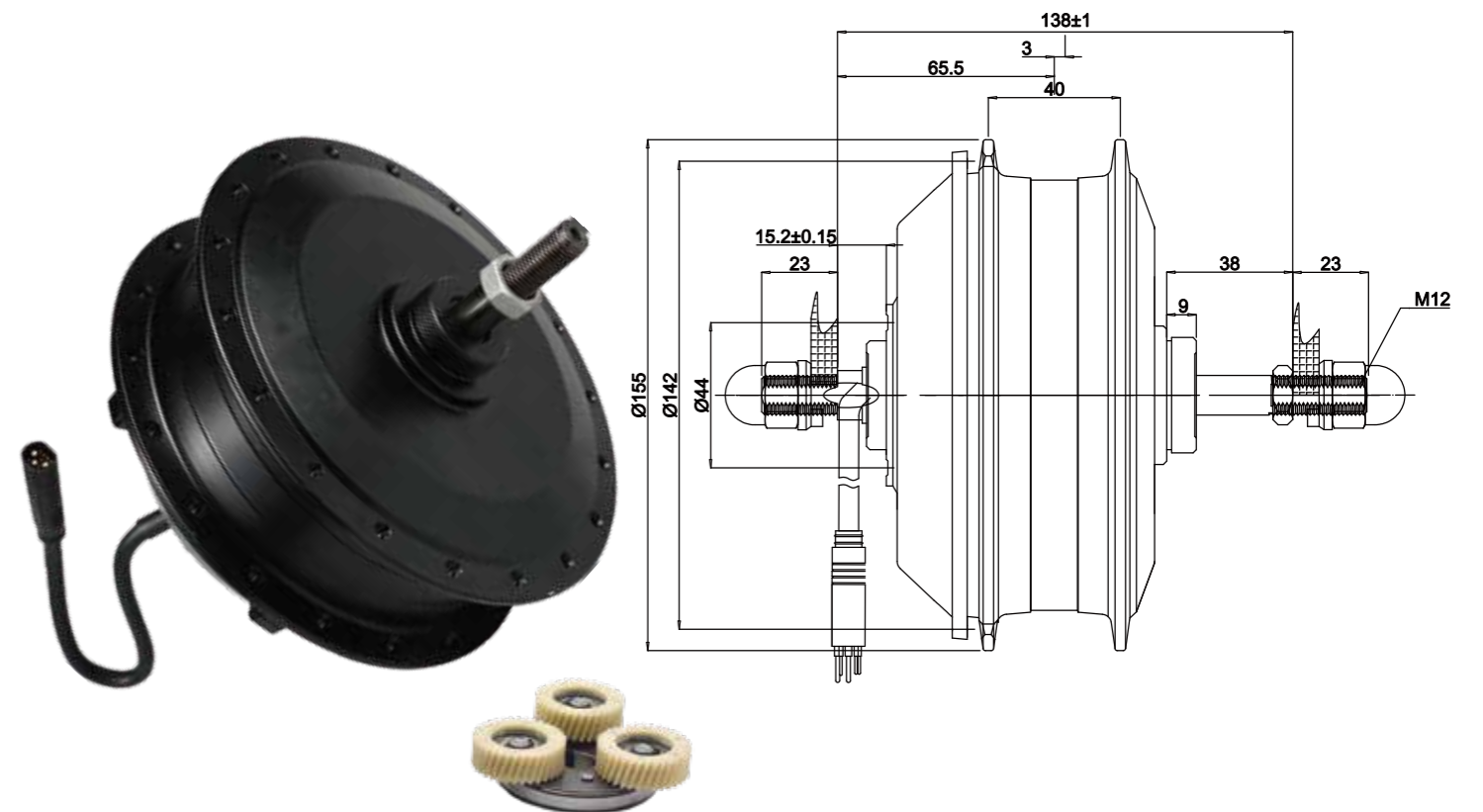

|                          |             |                                   |                      |
|--------------------------|-------------|-----------------------------------|----------------------|
| Position 安装位置            | Rear        | Dropout(mm)开档                     | 138                  |
| Construction电机结构         | Gear        | Brake Type 刹车类型                   | V/Disc brake         |
| Rated Voltage (V) 额定电压   | 24/36/48/60 | Operating Temperature (°C) 工作温度   | -20-45               |
| Rated Power (W) 额定功率     | 250-500     | Efficiency (%) 效率                 | ≥82                  |
| Weight (Kg) 重量           | 3.5         | Color颜色                           | Black/Shining/Silver |
| Reduction Ratio减速比       | 1:5.8       | Cable Location出线方式                | Shaft side left      |
| Max Torque (N.m) 最大扭矩    | 40          | Noise Grade (dB) 噪音等级             | ≤55db                |
| Wheel Diameter (Inch) 轮径 | 16-28       | IP Grade 防水等级                     | IP65                 |
| Rated Speed (km/h) 额定速度  | 25-35       | Salt spray Test Standard (h) 盐雾测试 | 24/96                |
| Spoke Specification 辐条   | 36H*12G/13G | Drive and Freewheel飞轮             | 6-7S                 |

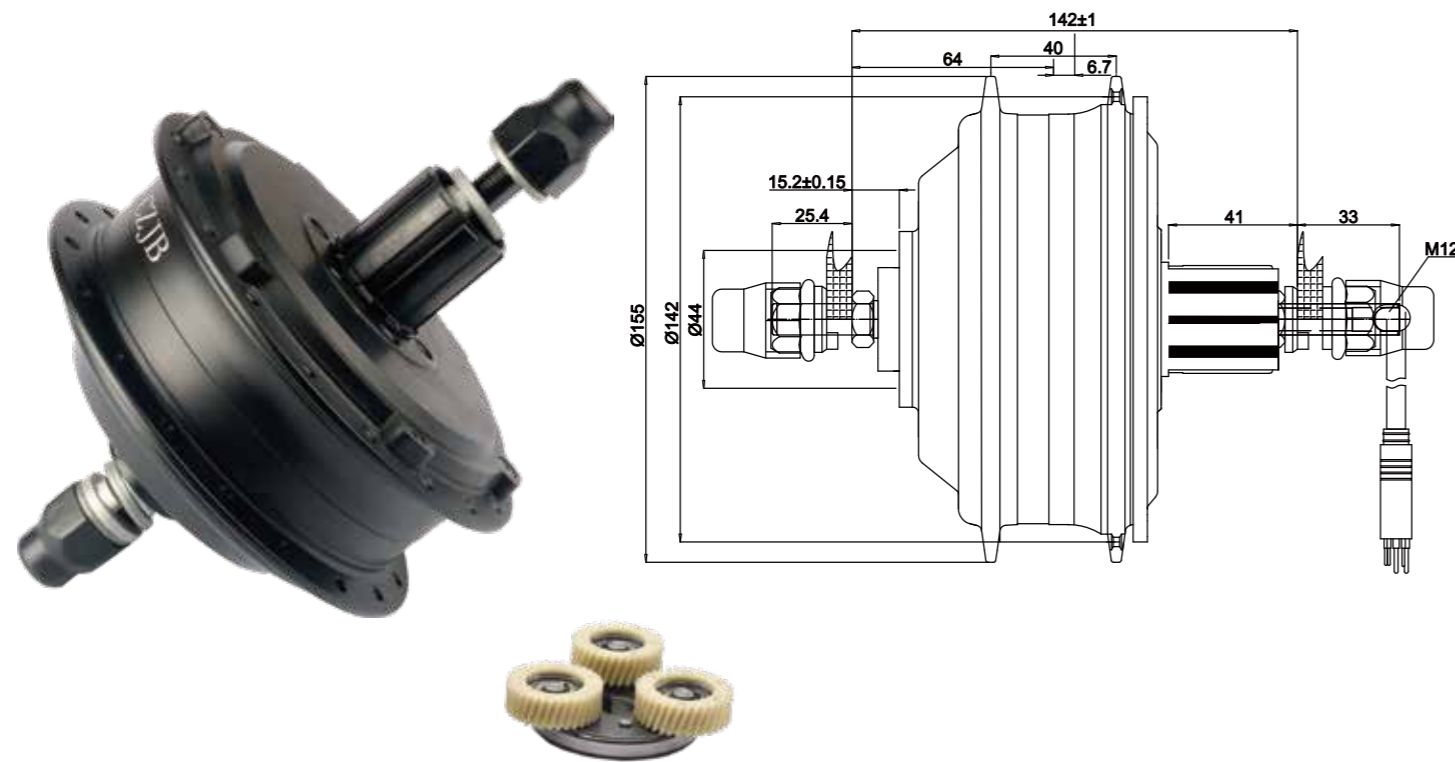

|                          |             |                                   |                      |
|--------------------------|-------------|-----------------------------------|----------------------|
| Position 安装位置            | Rear        | Dropout(mm)开档                     | 142                  |
| Construction电机结构         | Gear        | Brake Type 刹车类型                   | V/Disc brake         |
| Rated Voltage (V) 额定电压   | 24/36/48/60 | Operating Temperature (C) 工作温度    | -20-45               |
| Rated Power (W) 额定功率     | 250-500     | Efficiency (%) 效率                 | ≥82                  |
| Weight (Kg) 重量           | 3.5         | Color颜色                           | Black/Shining/Silver |
| Reduction Ratio减速比       | 1: 5.8      | Cable Location出线方式                | Shaft center right   |
| Max Torque (N.m) 最大扭矩    | 40          | Noise Grade (dB) 噪音等级             | ≤55db                |
| Wheel Diameter (Inch) 轮径 | 16-28       | IP Grade 防水等级                     | IP65                 |
| Rated Speed (km/h) 额定速度  | 25-35       | Salt spray Test Standard (h) 盐雾测试 | 24/96                |
| Spoke Specification 辐条   | 36H*12G/13G | Drive and Freewheel飞轮             | 8-9S                 |

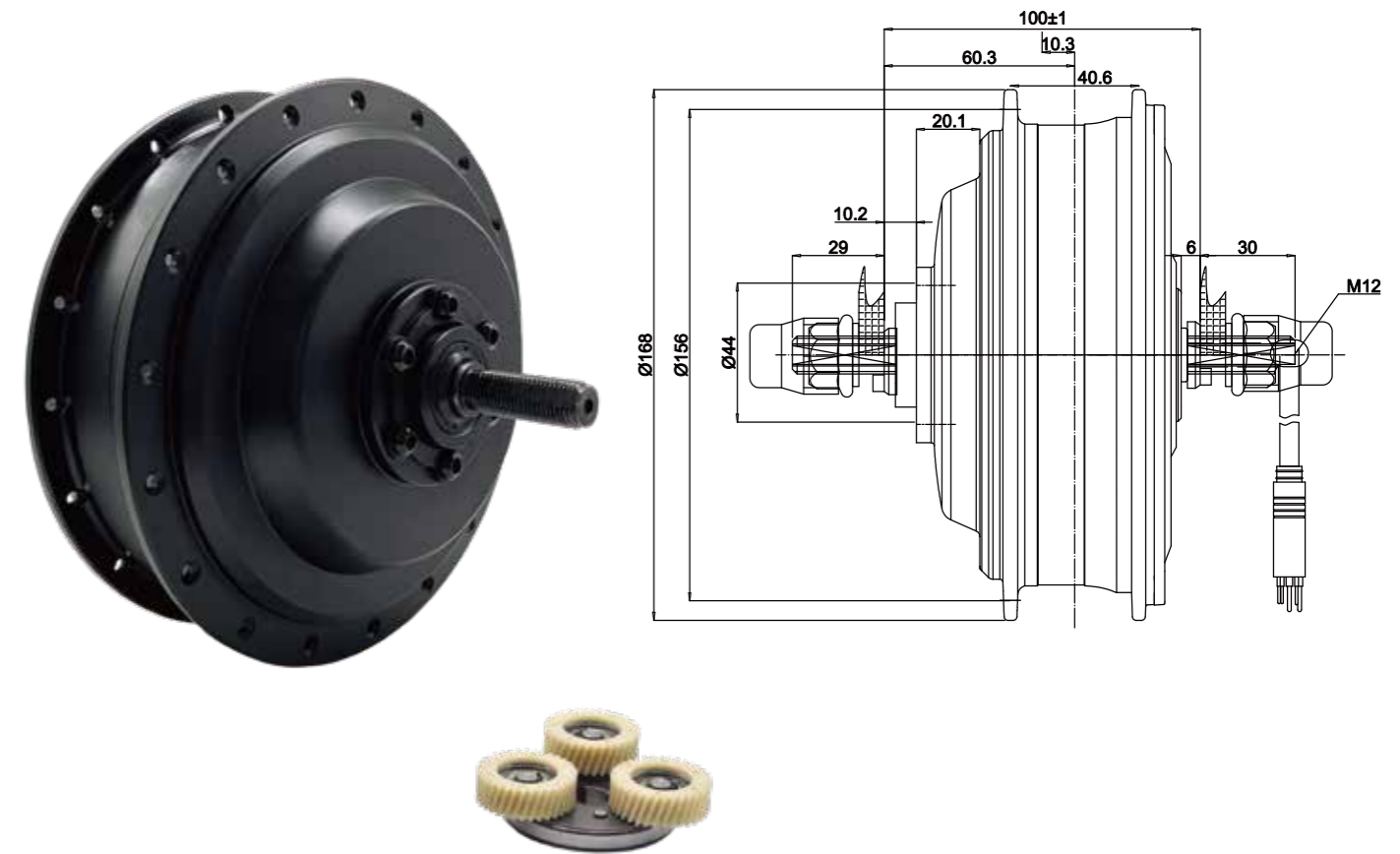

|                          |             |                                   |                       |
|--------------------------|-------------|-----------------------------------|-----------------------|
| Position 安装位置            | Front       | Dropout(mm)开档                     | 100                   |
| Construction电机结构         | Gear        | Brake Type 刹车类型                   | V/Disc brake          |
| Rated Voltage (V) 额定电压   | 36/48       | Operating Temperature (C) 工作温度    | -20-45                |
| Rated Power (W) 额定功率     | 500         | Efficiency (%) 效率                 | ≥82                   |
| Weight (Kg) 重量           | 3.5         | Color颜色                           | Black//Shining/Silver |
| Reduction Ratio减速比       | 1:5.2       | Cabling Route出线方式                 | Shaft center right    |
| Max Torque (N.m) 最大扭矩    | 60          | Noise Grade (dB) 噪音等级             | ≤55db                 |
| Wheel Diameter (Inch) 轮径 | 16-28       | IP Grade 防水等级                     | IP65                  |
| Rated Speed (km/h) 额定速度  | 25-35       | Salt spray Test Standard (h) 盐雾测试 | 24/96                 |
| Drive and Freewheel飞轮    | 36H*12G/13G | Drive and Freewheel飞轮             | /                     |



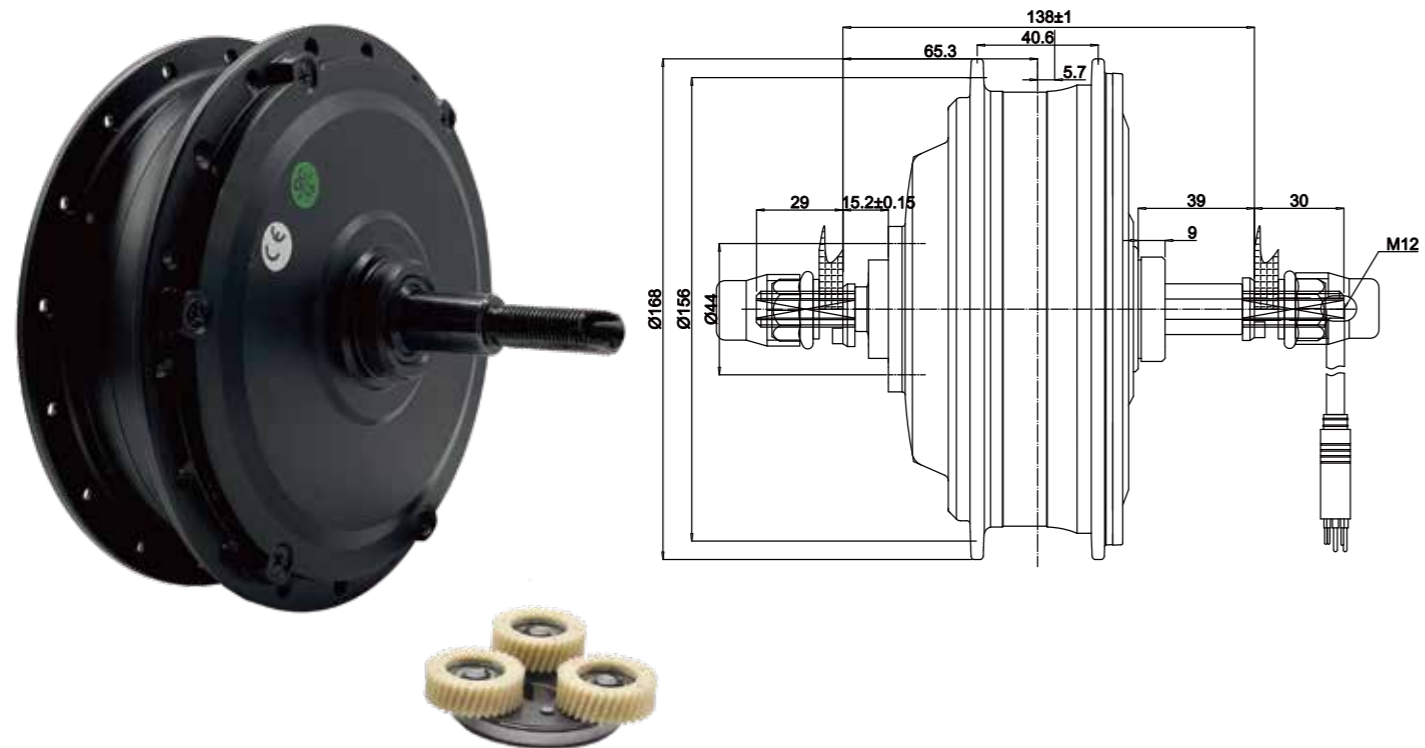

|                          |             |                                   |                       |
|--------------------------|-------------|-----------------------------------|-----------------------|
| Position 安装位置            | Rear        | Dropout(mm)开档                     | 138                   |
| Construction电机结构         | Gear        | Brake Type 刹车类型                   | V/Disc brake          |
| Rated Voltage (V) 额定电压   | 36/48       | Operating Temperature (C) 工作温度    | -20-45                |
| Rated Power (W) 额定功率     | 500         | Efficiency (%) 效率                 | ≥82                   |
| Weight (Kg) 重量           | 3.5         | Color颜色                           | Black//Shining/Silver |
| Reduction Ratio减速比       | 1:5.2       | Cable Location出线方式                | Shaft center right    |
| Max Torque (N.m) 最大扭矩    | 60          | Noise Grade (dB) 噪音等级             | ≤55db                 |
| Wheel Diameter (Inch) 轮径 | 16-28       | IP Grade 防水等级                     | IP65                  |
| Rated Speed (km/h) 额定速度  | 25-35       | Salt spray Test Standard (h) 盐雾测试 | 24/96                 |
| Drive and Freewheel飞轮    | 36H*12G/13G | Drive and Freewheel飞轮             | 6-7S                  |

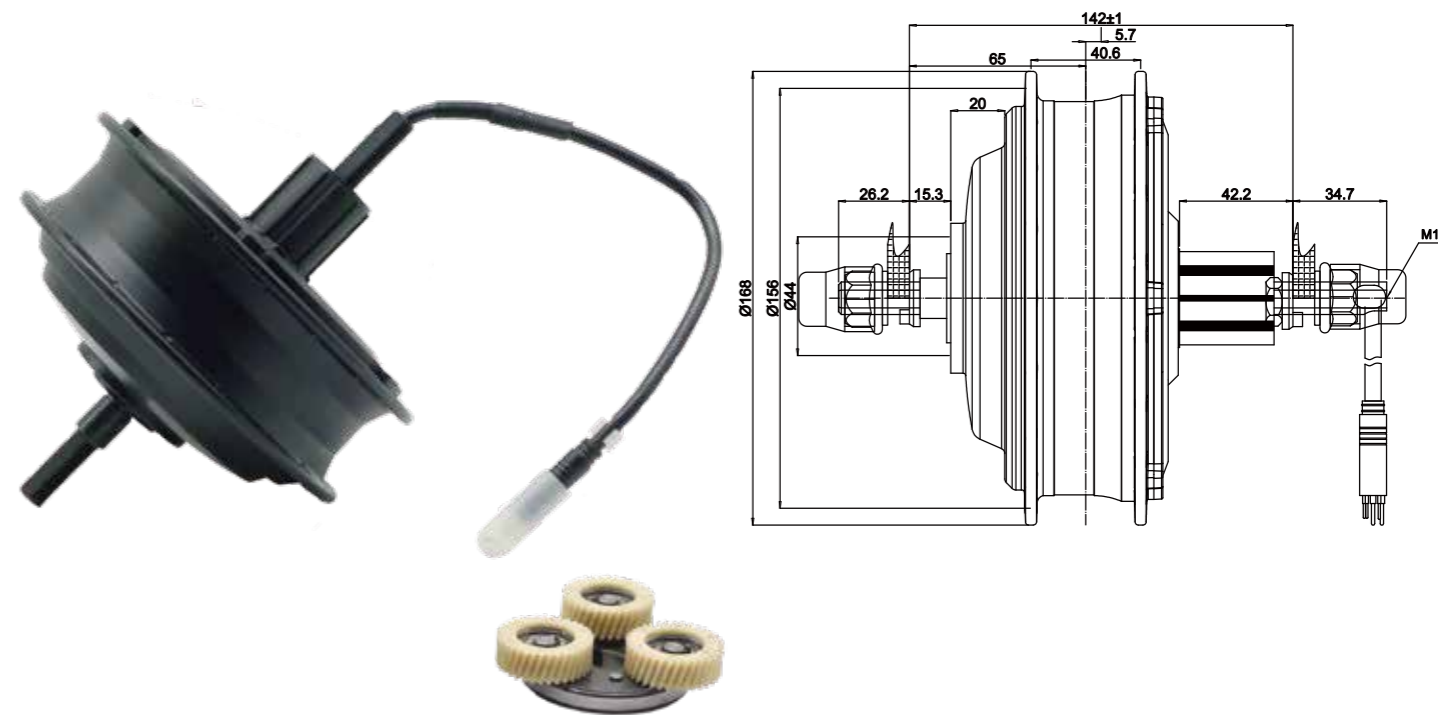

|                          |             |                                   |                       |
|--------------------------|-------------|-----------------------------------|-----------------------|
| Position 安装位置            | Rear        | Dropout(mm)开档                     | 142                   |
| Construction电机结构         | Gear        | Brake Type 刹车类型                   | V/Disc brake          |
| Rated Voltage (V) 额定电压   | 36/48       | Operating Temperature (C) 工作温度    | -20-45                |
| Rated Power (W) 额定功率     | 500         | Efficiency (%) 效率                 | ≥82                   |
| Weight (Kg) 重量           | 3.5         | Color颜色                           | Black//Shining/Silver |
| Reduction Ratio减速比       | 1:5.2       | Cable Location出线方式                | Shaft center right    |
| Max Torque (N.m) 最大扭矩    | 60          | Noise Grade (dB) 噪音等级             | ≤55db                 |
| Wheel Diameter (Inch) 轮径 | 16-28       | IP Grade 防水等级                     | IP65                  |
| Rated Speed (km/h) 额定速度  | 25-35       | Salt spray Test Standard (h) 盐雾测试 | 24/96                 |
| Drive and Freewheel飞轮    | 36H*12G/13G | Drive and Freewheel飞轮             | 8-9S                  |

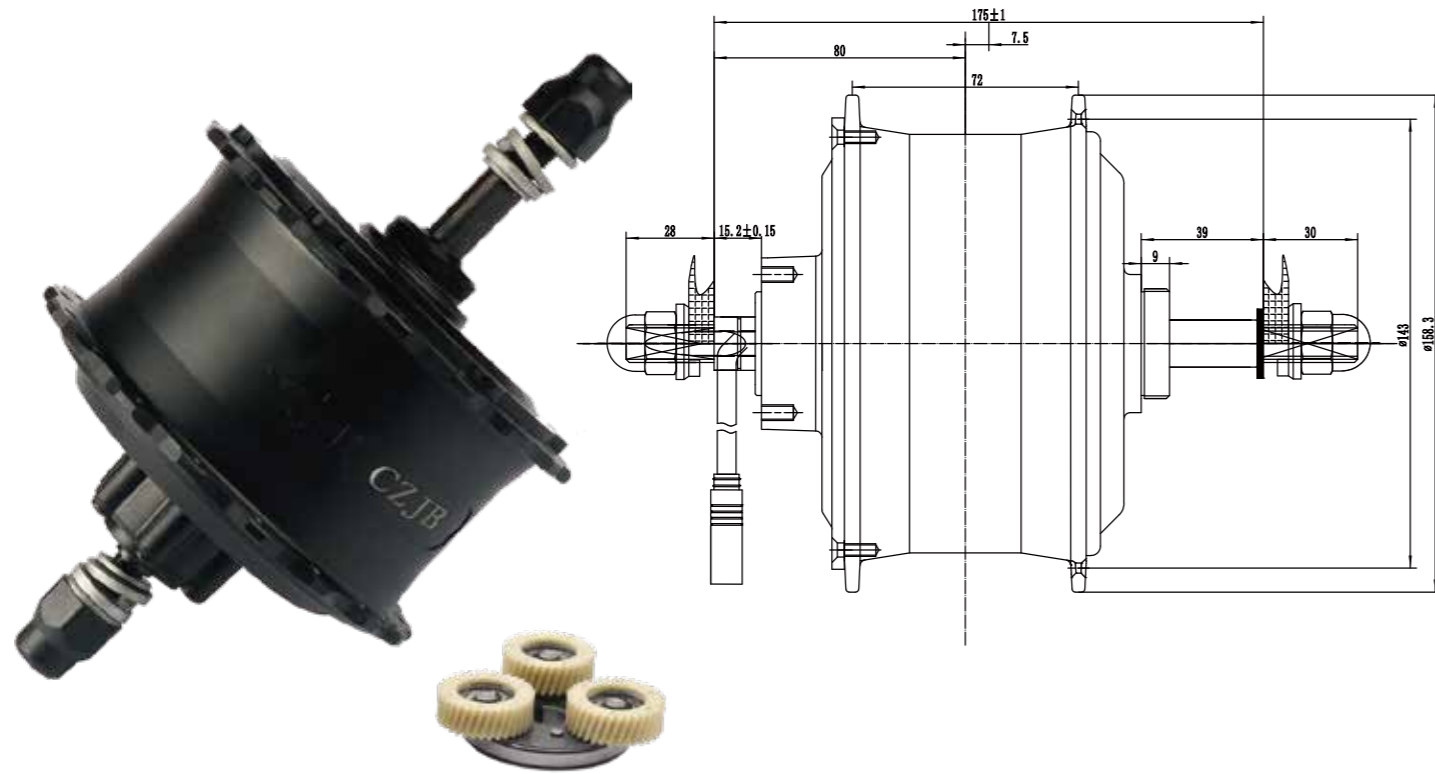

|                          |                             |                                   |                         |
|--------------------------|-----------------------------|-----------------------------------|-------------------------|
| Position 安装位置            | Rear                        | Dropout(mm)开档                     | 170-195                 |
| Construction电机结构         | Gear                        | Brake Type 刹车类型                   | V/Disc brake            |
| Rated Voltage (V) 额定电压   | 36/48/60                    | Operating Temperature (C) 工作温度    | -20-45                  |
| Rated Power (W) 额定功率     | 250-750                     | Efficiency (%) 效率                 | ≥82                     |
| Weight (Kg) 重量           | 4.0-4.5                     | Color颜色                           | Black//Shining/Silver   |
| Reduction Ratio减速比       | 350w1:5/500w1:5.2/750w1:5.8 | Cable Location出线方式                | Shaft center left/right |
| Max Torque (N.m) 最大扭矩    | 55                          | Noise Grade (dB) 噪音等级             | ≤55db                   |
| Wheel Diameter (Inch) 轮径 | 16-28                       | IP Grade 防水等级                     | IP65                    |
| Rated Speed (km/h) 额定速度  | 25-42                       | Salt spray Test Standard (h) 盐雾测试 | 24/96                   |
| Spoke Specification辐条    | 36H*12G/13G                 | Drive and Freewheel 飞轮            | 6-7S                    |

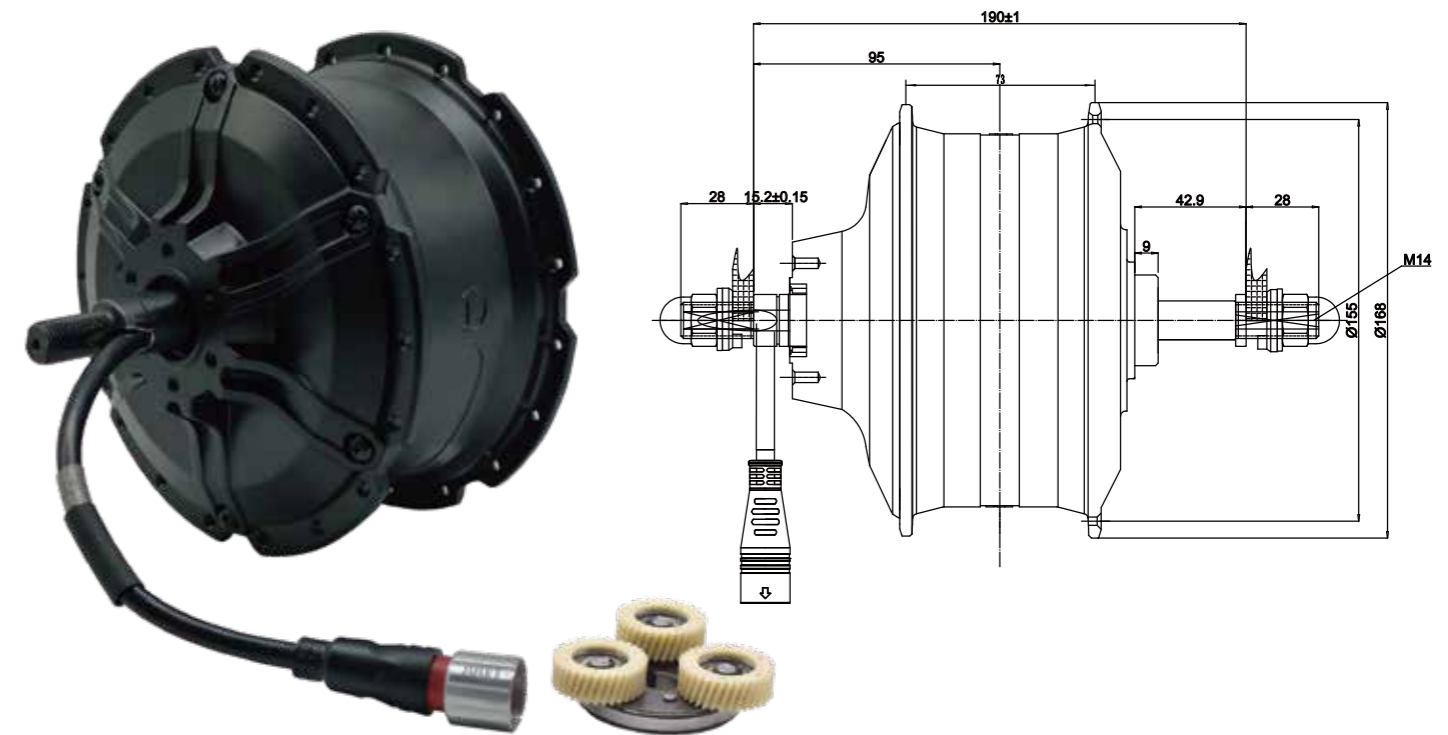

|                          |                                |                                   |                         |
|--------------------------|--------------------------------|-----------------------------------|-------------------------|
| Position 安装位置            | Rear                           | Dropout(mm)开档                     | 175/195                 |
| Construction电机结构         | Gear                           | Brake Type 刹车类型                   | V/Disc brake            |
| Rated Voltage (V) 额定电压   | 36/48/60                       | Operating Temperature (C) 工作温度    | -20-45                  |
| Rated Power (W) 额定功率     | 1000-1500W                     | Efficiency (%) 效率                 | ≥82                     |
| Weight (Kg) 重量           | 4.0-4.5                        | Color颜色                           | Black//Shining/Silver   |
| Reduction Ratio减速比       | 350w 1:5/500w 1:5.2/750w 1:5.8 | Cable Location出线方式                | Shaft center left/right |
| Max Torque (N.m) 最大扭矩    | 100                            | Noise Grade (dB) 噪音等级             | ≤55db                   |
| Wheel Diameter (Inch) 轮径 | 20-28                          | IP Grade 防水等级                     | IP65                    |
| Rated Speed (km/h) 额定速度  | 25-42                          | Salt spray Test Standard (h) 盐雾测试 | 24/96                   |
| Spoke Specification辐条    | 36H*12G/13G                    | Drive and Freewheel 飞轮            | 6-7S                    |

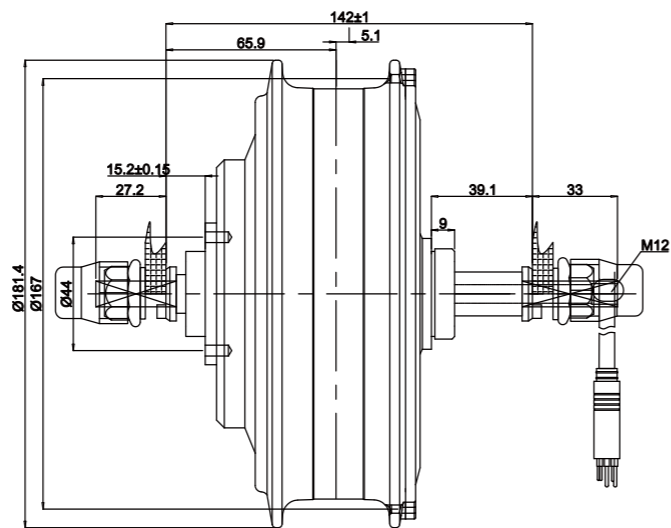

|                          |             |                                   |                      |
|--------------------------|-------------|-----------------------------------|----------------------|
| Position 安装位置            | Rear        | Dropout(mm)开档                     | 141                  |
| Construction电机结构         | Gear        | Brake Type 刹车类型                   | V/Disc brake         |
| Rated Voltage (V) 额定电压   | 24/36/48    | Operating Temperature (C) 工作温度    | -20-45               |
| Rated Power (W) 额定功率     | 800-1000    | Efficiency (%) 效率                 | ≥82                  |
| Weight (Kg) 重量           | 4           | Color颜色                           | Black/Shining/Silver |
| Reduction Ratio减速比       | 1:5.8       | Cable Location出线方式                | Shaft center right   |
| Max Torque (N.m) 最大扭矩    | 95          | Noise Grade (dB) 噪音等级             | ≤55db                |
| Wheel Diameter (Inch) 轮径 | 16-28       | IP Grade 防水等级                     | IP65                 |
| Rated Speed (km/h) 额定速度  | 25-45       | Salt spray Test Standard (h) 盐雾测试 | 24/96                |
| Spoke Specification 辐条   | 36H*12G/13G | Drive and Freewheel飞轮             | 6-7S                 |

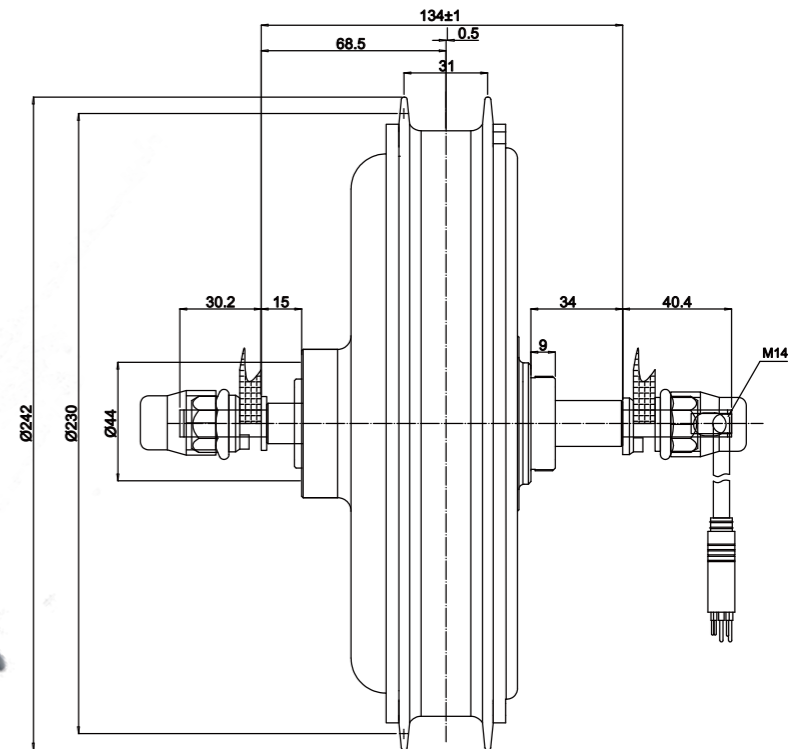

|                          |             |                                   |                         |
|--------------------------|-------------|-----------------------------------|-------------------------|
| Position 安装位置            | Front/Rear  | Dropout(mm)开档                     | front:100mm rear :135   |
| Construction电机结构         | Gearless    | Brake Type 刹车类型                   | V/Disc brake            |
| Rated Voltage (V) 额定电压   | 36/48/60/72 | Operating Temperature (C) 工作温度    | -20-45                  |
| Rated Power (W) 额定功率     | 350-1000    | Efficiency (%) 效率                 | ≥82                     |
| Weight (Kg) 重量           | 7           | Color颜色                           | Black/Silver            |
| Reduction Ratio减速比       | /           | Cable Location出线方式                | Shaft center left/right |
| Max Torque (N.m) 最大扭矩    | 45-55       | Noise Grade (dB) 噪音等级             | ≤55db                   |
| Wheel Diameter (Inch) 轮径 | 20-28       | IP Grade 防水等级                     | IP65                    |
| Rated Speed (km/h) 额定速度  | 25-45       | Salt spray Test Standard (h) 盐雾测试 | 24/96                   |
| Spoke Specification 辐条   | 36H*12G/13G | Drive and Freewheel飞轮             | 6-7S                    |



# 1000w gearless cassette motor

## 205-35H2

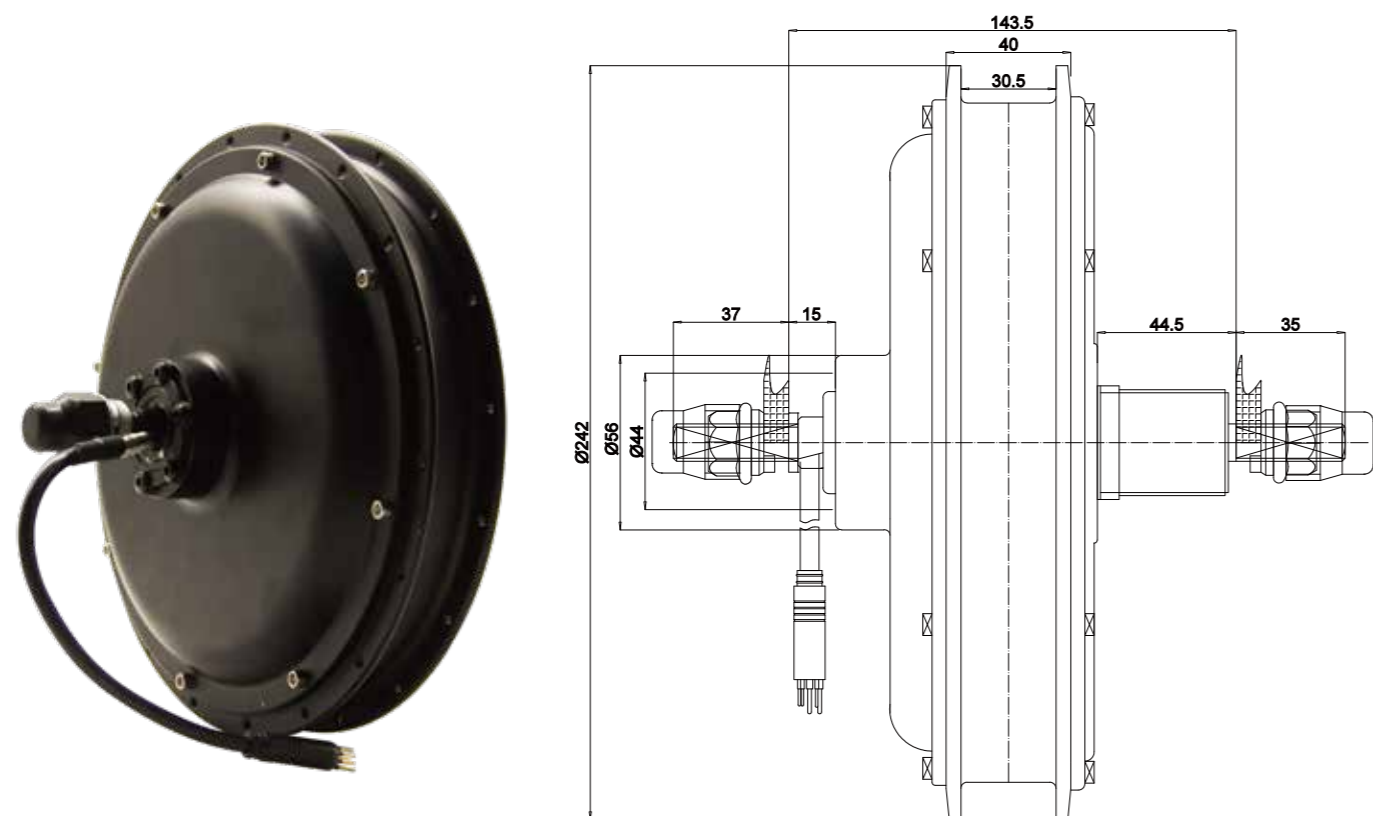

|                          |             |                                   |                 |
|--------------------------|-------------|-----------------------------------|-----------------|
| Position 安装位置            | Rear        | Dropout(mm)开档                     | 140             |
| Construction电机结构         | Gearless    | Brake Type 刹车类型                   | V/Disc brake    |
| Rated Voltage (V) 额定电压   | 36/48/60/72 | Operating Temperature (C) 工作温度    | -20-45          |
| Rated Power (W) 额定功率     | 350-1000    | Efficiency (%) 效率                 | ≥82             |
| Weight (Kg) 重量           | 7           | Color颜色                           | Black/Silver    |
| Reduction Ratio减速比       | /           | Cable Location出线方式                | Shaft side left |
| Max Torque (N.m) 最大扭矩    | 45-55       | Noise Grade (dB) 噪音等级             | ≤55db           |
| Wheel Diameter (Inch) 轮径 | 20-28       | IP Grade 防水等级                     | IP65            |
| Rated Speed (km/h) 额定速度  | 25-45       | Salt spray Test Standard (h) 盐雾测试 | 24/96           |
| Spoke Specification 辐条   | 36H*12G/13G | Drive and Freewheel飞轮             | 9S              |



# 1500w-3000w gearless motor

## 205-55

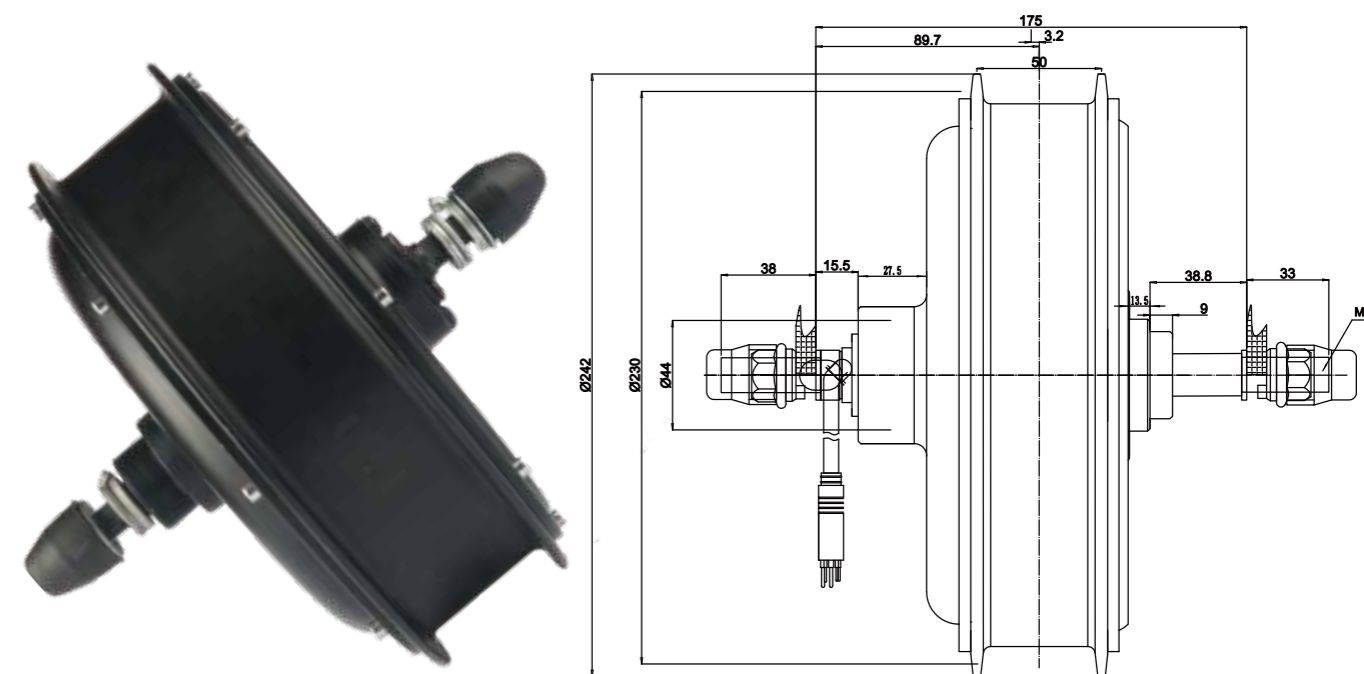

|                          |             |                                   |                 |
|--------------------------|-------------|-----------------------------------|-----------------|
| Position 安装位置            | Rear        | Dropout(mm)开档                     | 175             |
| Construction电机结构         | Gearless    | Brake Type 刹车类型                   | V/Disc brake    |
| Rated Voltage (V) 额定电压   | 36/48/60/72 | Operating Temperature (C) 工作温度    | -20-45          |
| Rated Power (W) 额定功率     | 350-3000    | Efficiency (%) 效率                 | ≥82             |
| Weight (Kg) 重量           | 7-11        | Color颜色                           | Black/Silver    |
| Reduction Ratio减速比       | /           | Cable Location出线方式                | Shaft side left |
| Max Torque (N.m) 最大扭矩    | 80          | Noise Grade (dB) 噪音等级             | ≤55db           |
| Wheel Diameter (Inch) 轮径 | 20-28       | IP Grade 防水等级                     | IP65            |
| Rated Speed (km/h) 额定速度  | 25-55       | Salt spray Test Standard (h) 盐雾测试 | 24/96           |
| Spoke Specification 辐条   | 36H*12G/13G | Drive and Freewheel飞轮             | 6-7S            |





|                          |          |                                   |                      |
|--------------------------|----------|-----------------------------------|----------------------|
| Position 安装位置            | Rear     | Dropout(mm)开档                     | 100                  |
| Construction电机结构         | Gear     | Brake Type 刹车类型                   | V/Disc brake         |
| Rated Voltage (V) 额定电压   | 24/36/48 | Operating Temperature (C) 工作温度    | -20-45               |
| Rated Power (W) 额定功率     | 180-350  | Efficiency (%) 效率                 | ≥82                  |
| Weight (Kg) 重量           | 3.2      | Color颜色                           | Black/Shining/Silver |
| Reduction Ratio减速比       | 1:4.35   | Cable Location出线方式                | Shaft center right   |
| Max Torque (N.m) 最大扭矩    | 32       | Noise Grade (dB) 噪音等级             | ≤55db                |
| Wheel Diameter (Inch) 轮径 | 12       | IP Grade 防水等级                     | IP65                 |
| Rated Speed (km/h) 额定速度  | 25       | Salt spray Test Standard (h) 盐雾测试 | 24/96                |

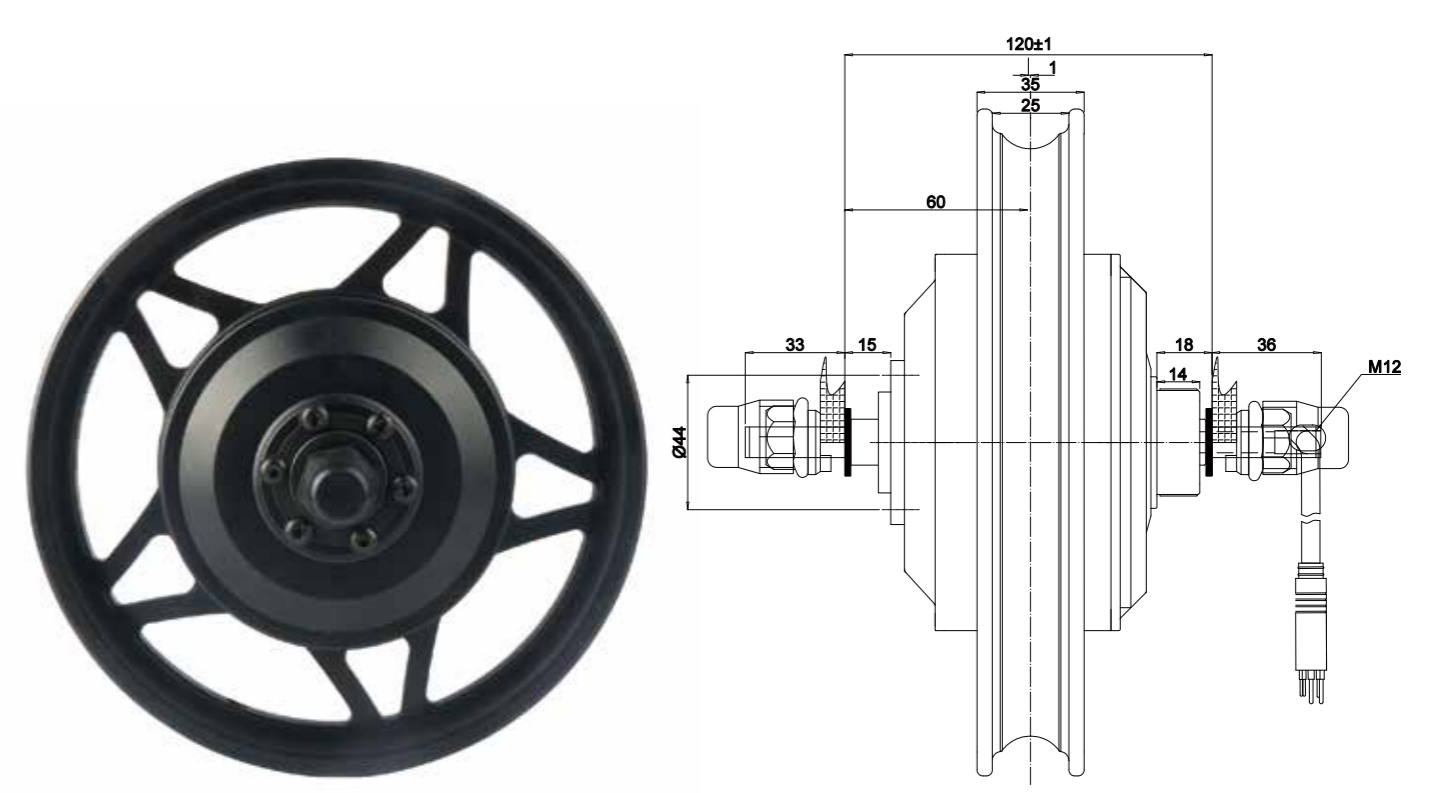

|                          |          |                                   |                       |
|--------------------------|----------|-----------------------------------|-----------------------|
| Position 安装位置            | Rear     | Dropout(mm)开档                     | 120                   |
| Construction电机结构         | Gear     | Brake Type 刹车类型                   | V/Disc brake          |
| Rated Voltage (V) 额定电压   | 24/36/48 | Operating Temperature (C) 工作温度    | -20-45                |
| Rated Power (W) 额定功率     | 180-350  | Efficiency (%) 效率                 | ≥82                   |
| Weight (Kg) 重量           | 3.2      | Color颜色                           | Black//Shining/Silver |
| Reduction Ratio减速比       | 1:4.4    | Cable Location出线方式                | Shaft center right    |
| Max Torque (N.m) 最大扭矩    | 30       | Noise Grade (dB) 噪音等级             | ≤55db                 |
| Wheel Diameter (Inch) 轮径 | 12       | IP Grade 防水等级                     | IP65                  |
| Rated Speed (km/h) 额定速度  | 25-30    | Salt spray Test Standard (h) 盐雾测试 | 24/96                 |
|                          |          | Drive and Freewheel飞轮             | 1S                    |



# 500w 16" gear fat tire wheel motor

## 104-16"

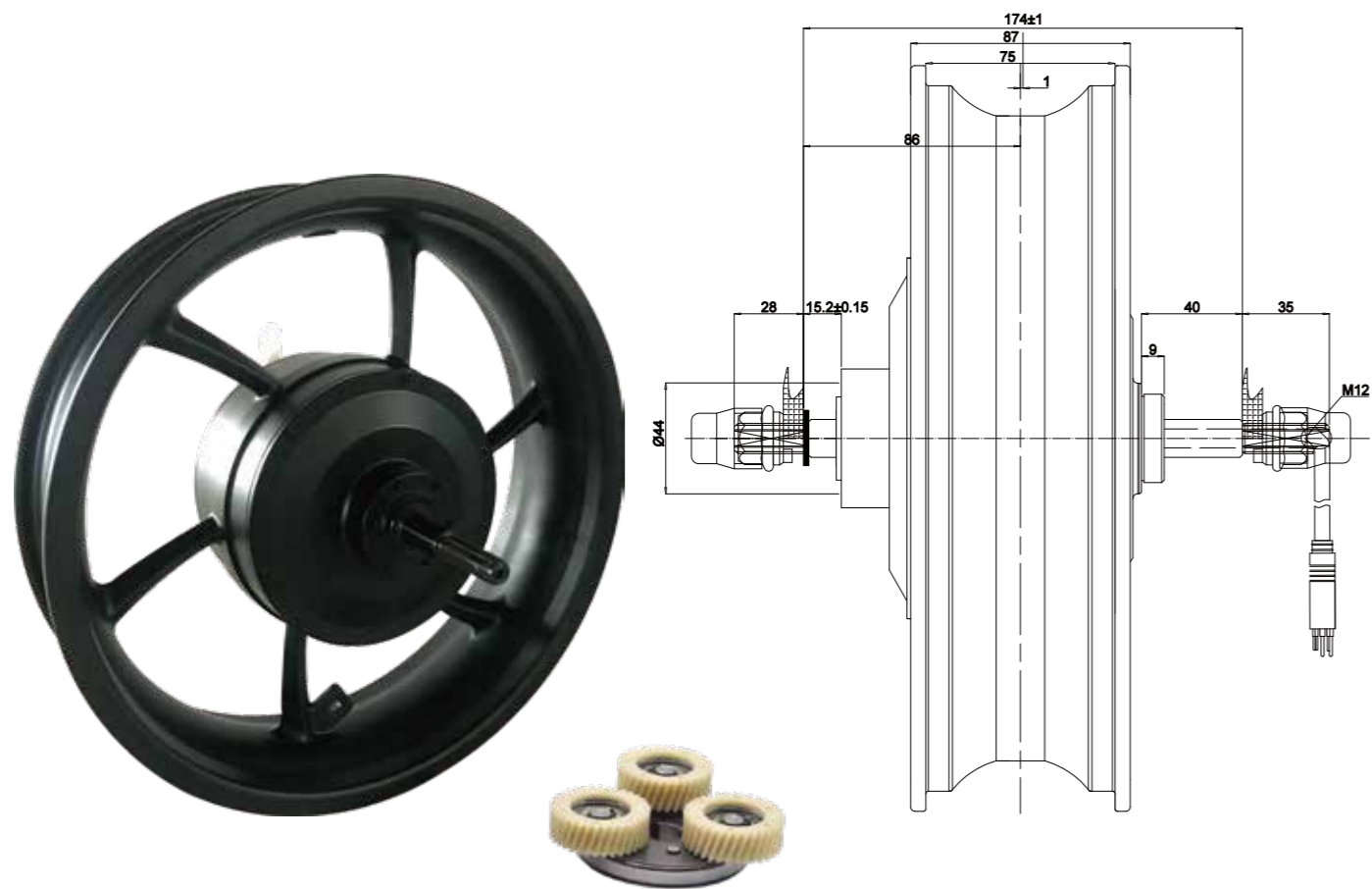

# 500w 20" gear fat tire wheel motor

## 104-20"

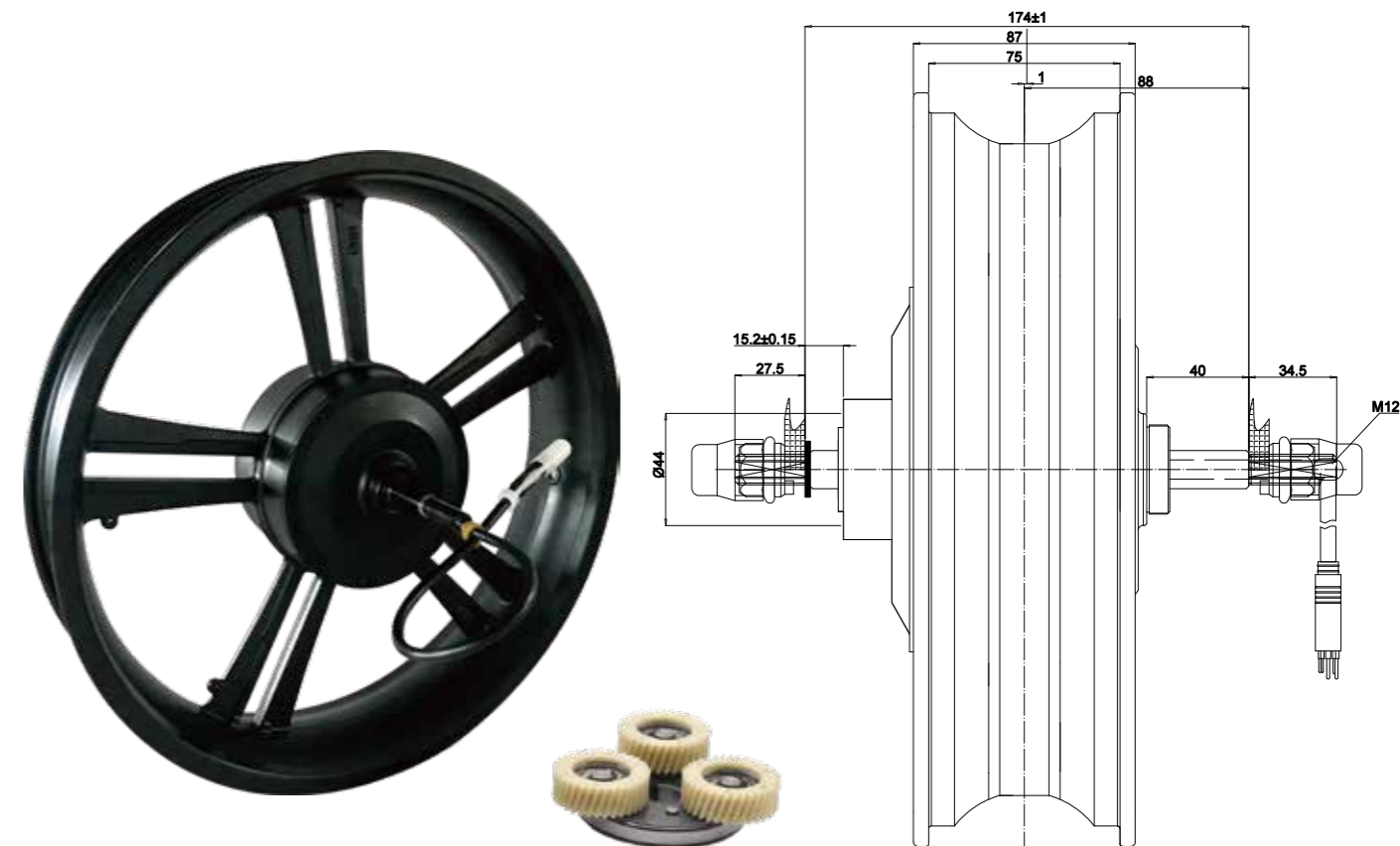





|                          |             |                                   |                       |
|--------------------------|-------------|-----------------------------------|-----------------------|
| Position 安装位置            | Rear        | Dropout(mm)开档                     | 175                   |
| Construction电机结构         | Gear        | Brake Type 刹车类型                   | V/Disc brake          |
| Rated Voltage (V) 额定电压   | 24/36/48/60 | Operation Temperature (C) 工作温度    | -20-45                |
| Rated Power (W) 额定功率     | 250-750     | Efficiency (%) 效率                 | ≥82                   |
| Weight (Kg) 重量           | 5           | Color颜色                           | Black//Shining/Silver |
| Reduction Ratio减速比       | 1:5.2       | Cable Location 出线方式               | Shaft center right    |
| Max Torque (N.m) 最大扭矩    | 55          | Noise Grade (dB) 噪音等级             | ≤55db                 |
| Wheel Diameter (Inch) 轮径 | 16          | IP Grade 防水等级                     | IP65                  |
| Rated Speed (km/h) 额定速度  | 25-35       | Salt spray Test Standard (h) 盐雾测试 | 24/96                 |
|                          |             | Drive and Freewheel飞轮             | 6-7S                  |

|                          |             |                                   |                       |
|--------------------------|-------------|-----------------------------------|-----------------------|
| Position 安装位置            | Rear        | Dropout(mm)开档                     | 175                   |
| Construction电机结构         | Gear        | Brake Type 刹车类型                   | V/Disc brake          |
| Rated Voltage (V) 额定电压   | 24/36/48/60 | Operation Temperature (C) 工作温度    | -20-45                |
| Rated Power (W) 额定功率     | 250-750     | Efficiency (%) 效率                 | ≥82                   |
| Weight (Kg) 重量           | 5           | Color颜色                           | Black//Shining/Silver |
| Reduction Ratio减速比       | 1:5.2       | Cable Location出线方式                | Shaft center right    |
| Max Torque (N.m) 最大扭矩    | 55          | Noise Grade (dB) 噪音等级             | ≤55db                 |
| Wheel Diameter (Inch) 轮径 | 20          | IP Grade 防水等级                     | IP65                  |
| Rated Speed (km/h) 额定速度  | 25-35       | Salt spray Test Standard (h) 盐雾测试 | 24/96                 |
|                          |             | Drive and Freewheel飞轮             | 6-7S                  |





## Electric Bicycle Kit

|   |  |
|---|--|
|    |    |
| <b>250W套件</b>   | <b>500W套件</b>  |
| <p>1/ Motor: 36v/48v 250w rear gear motor,25km/h (16-28")</p> <p>2/ Motor extension cable: 1.2*1000mm</p> <p>3/ Controller: sinewave 36/48v 13A-15A</p> <p>4/ Display: LED/LCD</p> <p>5/ Throttle: twist/thumb throttle</p> <p>6/ Brake lever: AL alloy with power cut off</p> <p>7/ E-bus cable: connect with display,brake lever,throttle</p> <p>8/ PAS: 1 :1 PAS,12 magnets/torque sensor</p> <p>9/ battery with charger: 36/48v lithium battery<br/>AC 100V-240V,2A smart charger</p> | <p>1/ Motor: 48v 500w rear gear motor,35km/h (16-28")</p> <p>2/ Motor extension cable: 1.5*1000mm</p> <p>3/ Controller: sinewave 48v 22A</p> <p>4/ Display: LED/LCD</p> <p>5/ Throttle: twist/thumb throttle</p> <p>6/ Brake lever: AL alloy with power cut off</p> <p>7/ E-bus cable: connect with display,brake lever,throttle</p> <p>8/ PAS: 1 :1 PAS,12 magnets/torque sensor</p> <p>9/ battery with charger: 48v lithium battery<br/>AC 100V-240V,2A smart charger</p>      |
|    |    |
| <b>750W套件</b>   | <b>1000W套件</b>   |
| <p>1/ Motor: 48v 750w rear gear motor,40km/h (16-28")</p> <p>2/ Motor extension cable: 2.0*1000mm</p> <p>3/ Controller: sinewave 48v 25A</p> <p>4/ Display: LED/LCD</p> <p>5/ Throttle: twist/thumb throttle</p> <p>6/ Brake lever: AL alloy with power cut off</p> <p>7/ E-bus cable: connect with display,brake lever,throttle</p> <p>8/ PAS: 1 :1 PAS,12 magnets/torque sensor</p> <p>9/ battery with charger: 48v lithium battery<br/>AC 100V-240V,2A smart charger</p>               | <p>1/ Motor: 48v 1000w rear gearless motor,50km/h (20-28")</p> <p>2/ Motor extension cable: 2.0*1000mm</p> <p>3/ Controller: sinewave 48v 30A</p> <p>4/ Display: LED/LCD</p> <p>5/ Throttle: twist/thumb throttle</p> <p>6/ Brake lever: AL alloy with power cut off</p> <p>7/ E-bus cable: connect with display,brake lever,throttle</p> <p>8/ PAS: 1 :1 PAS,12 magnets/torque sensor</p> <p>9/ battery with charger: 48v lithium battery<br/>AC 100V-240V,2A smart charger</p> |

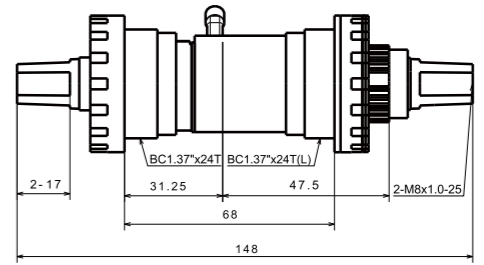

## Torque Sensor

|                       |   |
|-----------------------|---|
| Appearance外观          |  |
| Size 尺寸               |  |
| Model No.型号           | TKTM/01   |
| Input Voltage(V)供电电压  | 3.8-5.5   |
| Output Voltage(V)输出电压 | 0.75-3.6  |
| Current(W)电流          | < 0.014   |
| Signals(P)速度信号        | 32  |
| Resolution(N.m)扭矩     | 0-85  |
| Resolution(mV/N.m)灵敏度 | 35  |
| Temperature( C)温度     | -20 - 85 C  |
| Weight(g)重量           | 500   |
| BB Width(mm)宽度        | 68/73/84/100  |
| Mounting Position安装位置 | Bottom Bracket五通管   |
| Waterproof Grade防水等级  | IP65  |

*New products or other products, please check our website and contact our sales!*



佳博机械提供给大众的不仅仅是产品,更是它基于整体解决方案的全面服务。公司在各大城市中设有销售技术服务中心,为用户提供全方位的售前、售中、售后服务,能够及时响应用户的各种需求,做到真正解决用户的后顾之忧。

自信源于专业,品质源于责任!佳博机械将以“诚信为本、专业服务、双赢合作、共同发展”为理念,为用户提供更出色的产品和服务,为构筑更完善的行业体系永续动力。

We not only provide products, but also the whole solution of comprehensive service center in each big city all round China, providing complete pre-sale, after sale service for the user, and respond to the various needs of the users.

Confidence comes from the professional and quality come from the responsibility! Changzhou Jiabo Machinery Manufacturing Co., Ltd. will adhere to the concept of “Good Faith, Professional Service, Win-win Cooperation, Common Development”, to provide more excellent products and service for all our customer, as to build a more perfect system of sustainable power for the Industry system community.

