



**常州市佳博机械制造有限公司**

电 话: 0086-519-86133523  
传 真: 0086-519-86135153  
地 址: 常州武进前黄运村农场村  
邮 箱: bikemotor@czjbmotor.com  
网 址: <http://www.czjb.com>

**Changzhou JiaBo Machinery Manufacturing Co.,Ltd.**

Tel:0086-519-86511997  
Fax:0086-519-86135153  
E-mail:bikemotor@czjbmotor.com  
Add:Nongchang,Yuncun vill,Qianhuang Town,  
Wujin Dist,Changzhou City  
Web:<http://www.czjb.com>

**CZJB MOTOR AMERICA SERVICE**

Contact :Esperanza  
Tel: 9493167462  
E-mail:sales3@jiabo-motor.com  
Address:9439 Archibald Ave #101,  
Rancho Cucamonga,CA 91730

# 企业简介

## COMPANY PROFILE



Changzhou Jiabo Machinery Manufacturing Co., Ltd. was established in 2008 as a high-tech company integrating product development, production and sales.

The company mainly produces electric bicycle hub motors, mid-drive motors, and torque sensor. We also supply electric bike conversion kit include controller, display, throttle, brake lever, pas and waterproof connected cables.

Our company has experienced product development designers who can develop customized motor products with special requirements in response to the different needs of customers. Based on the principle of customer consideration and environmental protection, the company uses good raw materials and exquisite production technology to create stable, efficient and durable products for customers.

The factory covers an area of more than 15,000 square meters and has an annual production capacity of 800,000 units. The products have passed CCC, CE, ROHS, EMC, SGS, UKCA. and many other international certifications. We have established a complete quality assurance system and passed the ISO9001 quality system certification.

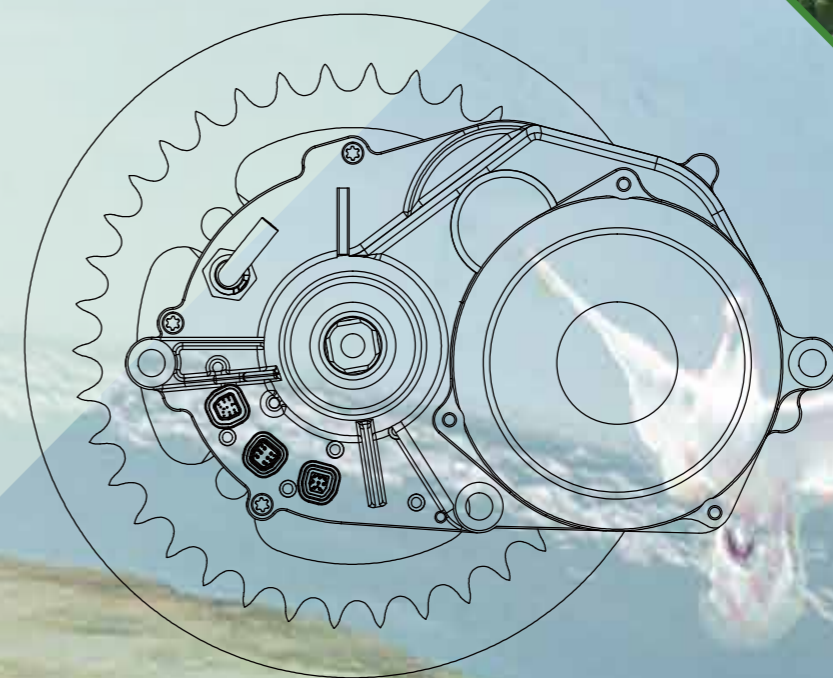

# 目 录

Contents

# 目 录

Contents



中置电机 Mid drive motor 250w-500w	
MM02 -----	01
CS500-1三轮车集成驱动-----	02

轻量内转子电机 250w motor for E-city	
IH45H01 -----	03
90N3 内3速电机 -----	04



外转子电机 250w motor for E-city	
75Q -----	05
75A -----	06
75T -----	07
75T2 -----	08

外转子电机 250w-350w motor for E-city/mtb/road	
90TQ -----	09
90T皮带轮-----	10
90SZ -----	11



外转子电机 250w-350w motor for E-city/mtb/road	
90T2 -----	12
90C -----	13
90A3X-----	14



外转子电机 350w-500w motor E-city/road	
110SZ -----	15
105CQ -----	16
105C -----	17
105C2 -----	18

外转子电机 350w-500w motor E-city/road	
105CZ -----	19
121TQ -----	20
121T -----	21
121T2-----	22



雪地车电机 350w-1500w motor E-fat	
110DZ -----	23
110CQ-----	24
110CS -----	25
121CZ -----	26
135CZ -----	27



电机 350w-1000w motor E-MTB	
135T -----	28
205/35 -----	29
205/35H2 -----	30
205/55 -----	31



一体轮电机 wheel hub motor 250w-750w	
90/12" -----	32
90/14" -----	33
90/16" -----	34
104/16" -----	35
90/20" -----	36
104/20" -----	37



电机套件 E-bike kit	
电机套件 E-bike kit 250w-1000w-----	38
中轴力矩 Torque sensor -----	39
全自动修车架 EBIKE REPAIR STAND -----	40



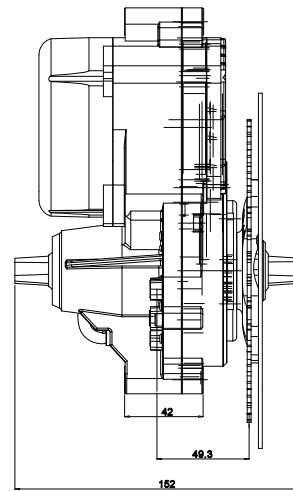
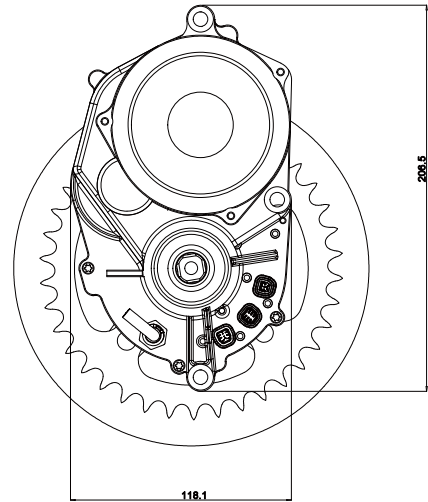

Rated Voltage (V) 额定电压	36/48	Operating Temperature (°C) 工作温度	-20-45
Rated Power (W) 额定功率	350-500	Efficiency (%) 效率	≥ 82
Weight (Kg) 重量	3.82	Color颜色	Black
Reduction Ratio减速比	1:32.58	Noise Grade (dB) 噪音等级	≤ 55db
Torque (N.m) 最大扭矩	150	IP Grade 防水等级	IP65
Rated Speed (RPM) 额定转速	80-100	Salt spray Test Standard (h) 盐雾测试	24/96
Sensor传感器	Speed&torque sensor		



Rated Voltage (V) 额定电压	48
Rated Power (W) 额定功率	500W/750W
Weight (Kg) 重量	5.25
Reduction Ratio 减速比	1: 18.5
Max Torque (N.m) 最大扭矩	75/90N.m

最新版传动系统将差速器和电机融合成一体，实现了多项优化：

减少系统体积和重量，简化整车厂安装过程。

通过降低能量损失，提高动力传输效率，使得续航里程增加至30%。

该系统更可靠、更耐用，减少了转速和扭矩的波动，为驾驶者带来更加平稳舒适的驾驶体验。

The latest TRI DRIVE FUSION SYSTEM integrates the differential and motor, optimizing performance: reducing size and weight, simplifying assembly.

boosting efficiency to increase range by 30%.

It's more reliable, durable, and provides a smoother, comfortable driving experience with reduced speed and torque fluctuations.



Installation position 安装位置	rear 后轮
Transmission type 变速方式	Automatic 自动
Number of gears 变速级数	3
Reduction Ratio 电机减速比	1:5.8
Internal 3 speed Ratio 内三速减速比	1: 1.3: 1.7
Weight (Kg) 重量	3.8

灵活性高：多档位设计，根据骑手需求提供合适的动力输出，增强骑行的灵活性和舒适性。  
省力骑行：自动调整档位，轻松适应不同路况和坡度，减少骑行者的疲劳感。  
平稳性好：换挡平稳，无明显的动力中断或颠簸感，提高了骑行的舒适性和稳定性。

High flexibility: Multi-gear design adjusts power output for enhanced riding comfort.  
Effortless riding: Automatic gear adjustment adapts to various terrains, reducing fatigue.  
Excellent stability: Smooth gear shifts enhance comfort and stability.



# 250w motor 轻量内转子 旋飞/卡飞/皮带轮

# IH45H01

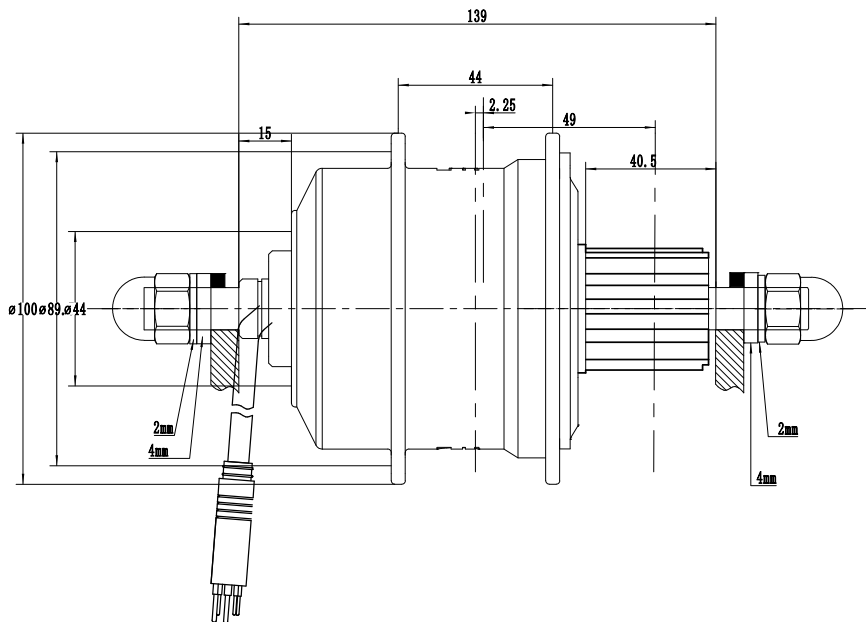

Position 安装位置	Rear	Dropout(mm)开档	135/138
Construction电机结构	Gear	Brake Type 刹车类型	V/Disc brake
Rated Voltage (V) 额定电压	36	Operating Temperature (°C) 工作温度	-20-45
Rated Power (W) 额定功率	250	Efficiency (%) 效率	≥82
Weight (Kg) 重量	1.6	Color颜色	Black/Silver
Reduction Ratio减速比	1: 12	Cable Location出线方式	Shaft side left
Max Torque (N.m) 最大扭矩	35	Noise Grade (dB) 噪音等级	≤55db
Wheel Diameter (Inch) 轮径	16-28	IP Grade 防水等级	IP65
Rated Speed (km/h) 额定速度	25	Salt spray Test Standard (h) 盐雾测试	24/96
Spoke Specification 辐条	36H*12G/13G	Drive and Freewheel飞轮	6-7S/9S





# 250w front motor

# 75Q

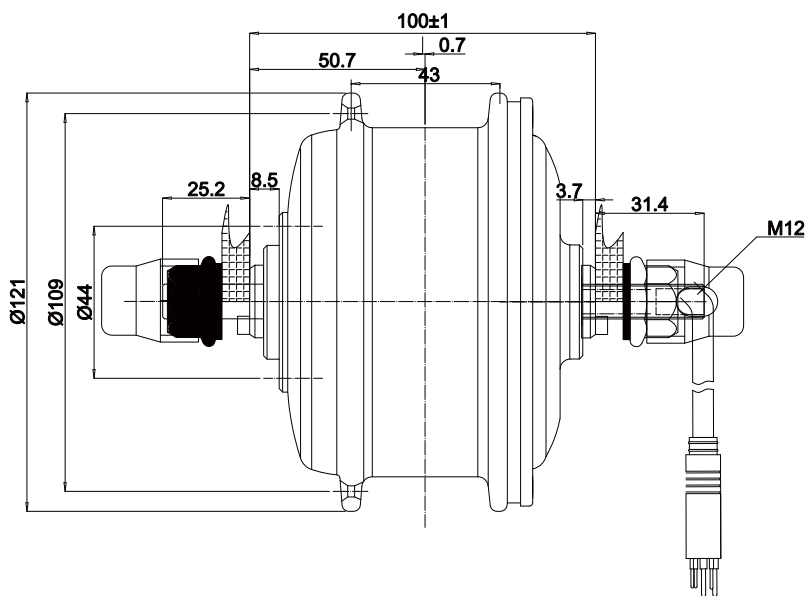

Position 安装位置	Front	Dropout(mm)开档	100
Construction电机结构	Gear	Brake Type 刹车类型	V/Disc brake
Rated Voltage (V) 额定电压	24/36/48	Operating Temperature (C) 工作温度	-20-45
Rated Power (W) 额定功率	180-250	Efficiency (%) 效率	≥82
Weight (Kg) 重量	1.9	Color颜色	Black/Silver
Reduction Ratio减速比	1:4.35	Cable Location出线方式	Shaft center right
Max Torque (N.m) 最大扭矩	35	Noise Grade (dB) 噪音等级	≤55db
Wheel Diameter (Inch) 轮径	16-28	IP Grade 防水等级	IP65
Rated Speed (km/h) 额定速度	25	Salt spray Test Standard (h) 盐雾测试	24/96
Spoke Specification辐条	36H*12G/13G	Drive and Freewheel飞轮	/





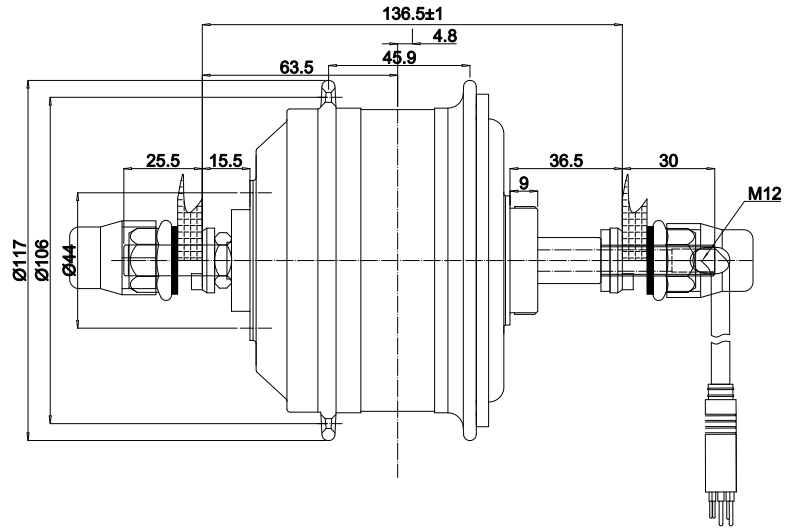

Position 安装位置	Rear	Dropout(mm)开档	136
Construction电机结构	Gear	Brake Type 刹车类型	V/Disc brake
Rated Voltage (V) 额定电压	24/36/48	Operating Temperature (°C) 工作温度	-20-45
Rated Power (W) 额定功率	180-250	Efficiency (%) 效率	≥82
Weight (Kg) 重量	1.9	Color颜色	Black/Silver
Reduction Ratio减速比	1:4.4	Cable Location出线方式	Shaft center right
Max Torque (N.m) 最大扭矩	35	Noise Grade (dB) 噪音等级	≤55db
Wheel Diameter (Inch) 轮径	16-28	IP Grade 防水等级	IP65
Rated Speed (km/h) 额定速度	25	Salt spray Test Standard (h) 盐雾测试	24/96
Spoke Specification辐条	36H*12G/13G	Drive and Freewheel飞轮	6-7S





# 250w motor

# 75T

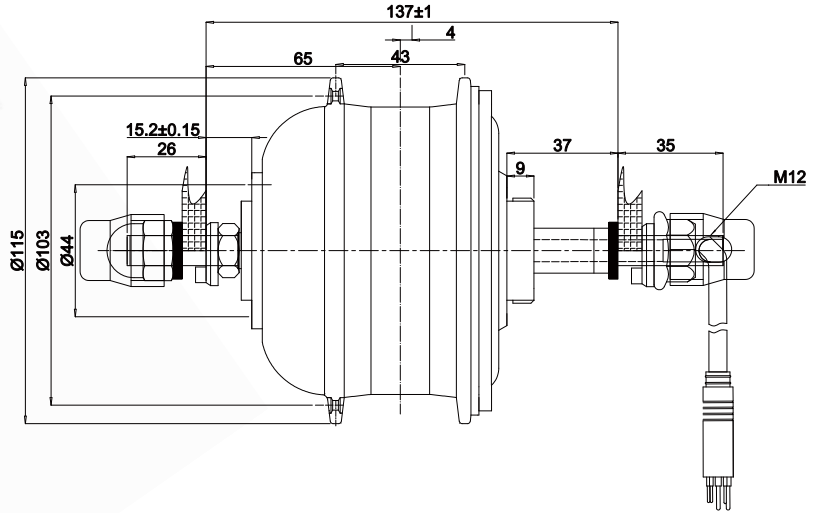

Position 安装位置	Rear	Dropout(mm)开档	137
Construction电机结构	Gear	Brake Type 刹车类型	V/Disc brake
Rated Voltage (V) 额定电压	24/36/48	Operating Temperature (°C) 工作温度	-20-45
Rated Power (W) 额定功率	180-320	Efficiency (%) 效率	≥82
Weight (Kg) 重量	2.2	Color颜色	Black/Silver
Reduction Ratio减速比	1:6.1	Cable Location出线方式	Shaft center right
Max Torque (N.m) 最大扭矩	40	Noise Grade (dB) 噪音等级	≤55db
Wheel Diameter (Inch) 轮径	16-28	IP Grade 防水等级	IP65
Rated Speed (km/h) 额定速度	25	Salt spray Test Standard (h) 盐雾测试	24/96
Spoke Specification辐条	36H*12G/13G	Drive and Freewheel飞轮	6-7S



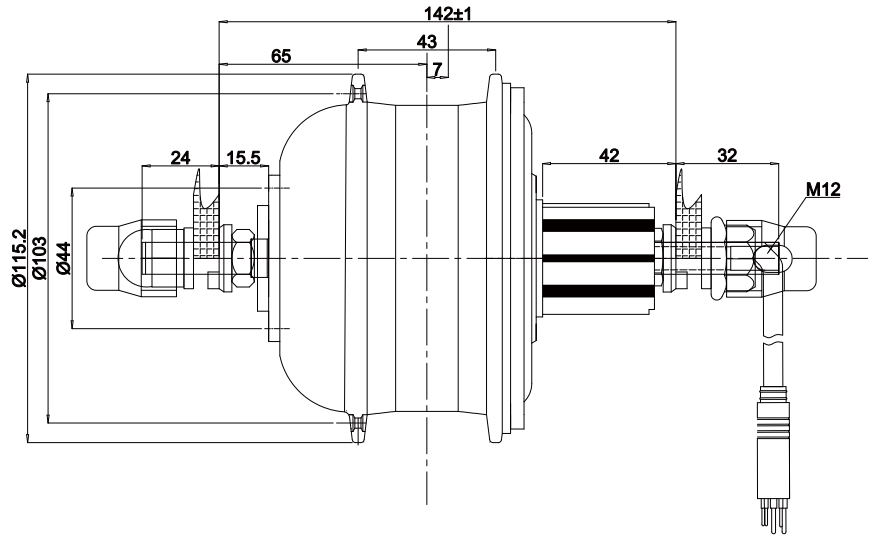

Position 安装位置	Rear	Dropout(mm)开档	142
Construction电机结构	Gear	Brake Type 刹车类型	V/Disc brake
Rated Voltage (V) 额定电压	24/36/48	Operating Temperature (°C) 工作温度	-20-45
Rated Power (W) 额定功率	180-320	Efficiency (%) 效率	≥82
Weight (Kg) 重量	2.2	Color颜色	Black/Silver
Reduction Ratio减速比	1:6.1	Cable Location出线方式	Shaft center right
Max Torque (N.m) 最大扭矩	40	Noise Grade (dB) 噪音等级	≤55db
Wheel Diameter (Inch) 轮径	16-28	IP Grade 防水等级	IP65
Rated Speed (km/h) 额定速度	25	Salt spray Test Standard (h) 盐雾测试	24/96
Spoke Specification辐条	36H*12G/13G	Drive and Freewheel飞轮	9S



# 250-350w front motor

# 90TQ

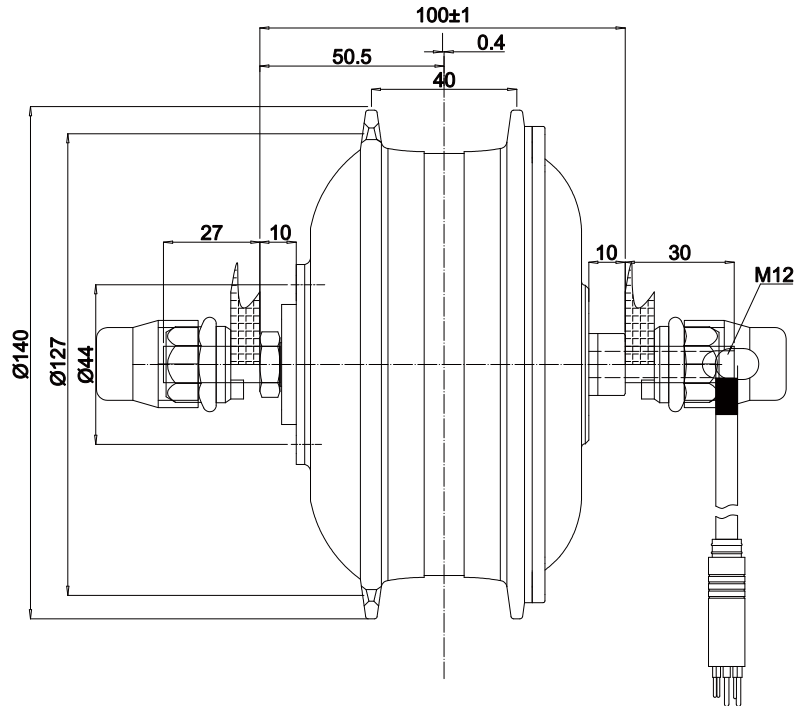

Position 安装位置	Front	Dropout(mm)开档	100
Construction电机结构	Gear	Brake Type 刹车类型	V/Disc brake
Rated Voltage (V) 额定电压	24/36/48	Operating Temperature (°C) 工作温度	-20-45
Rated Power (W) 额定功率	180-350	Efficiency (%) 效率	≥ 82
Weight (Kg) 重量	2.8	Color颜色	Black/Silver
Reduction Ratio减速比	1:5.2	Cable Location出线方式	Shaft side right
Max Torque (N.m) 最大扭矩	40	Noise Grade (dB) 噪音等级	≤ 55db
Wheel Diameter (Inch) 轮径	16-28	IP Grade 防水等级	IP65
Rated Speed (km/h) 额定速度	25	Salt spray Test Standard (h) 盐雾测试	24/96
Spoke Specification辐条	36H*12G/13G	Drive and Freewheel飞轮	/





# 250-350w belt motor

# 90T旋飞/皮带轮

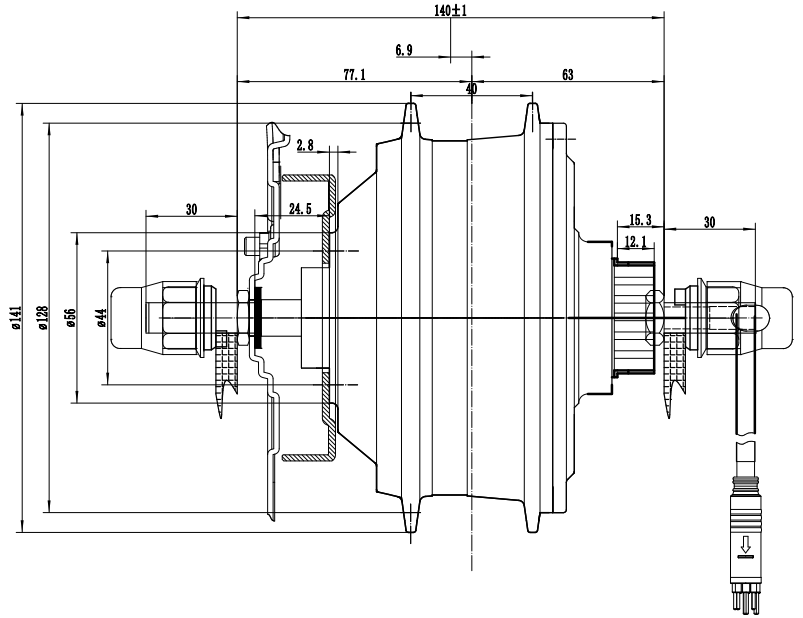

Position 安装位置	Rear	Dropout(mm)开档	137
Construction电机结构	Gear	Brake Type 刹车类型	V/Disc brake
Rated Voltage (V) 额定电压	24/36/48	Operating Temperature (°C) 工作温度	-20-45
Rated Power (W) 额定功率	180-350	Efficiency (%) 效率	≥82
Weight (Kg) 重量	3	Color颜色	Black/Silver
Reduction Ratio减速比	1:5.2	Cable Location出线方式	Shaft center right
Max Torque (N.m) 最大扭矩	40	Noise Grade (dB) 噪音等级	≤55db
Wheel Diameter (Inch) 轮径	16-28	IP Grade 防水等级	IP65
Rated Speed (km/h) 额定速度	25	Salt spray Test Standard (h) 盐雾测试	24/96
Spoke Specification辐条	36H*12G/13G	Drive and Freewheel 飞轮	6-7S





# 250w -350w motor

# 90SZ

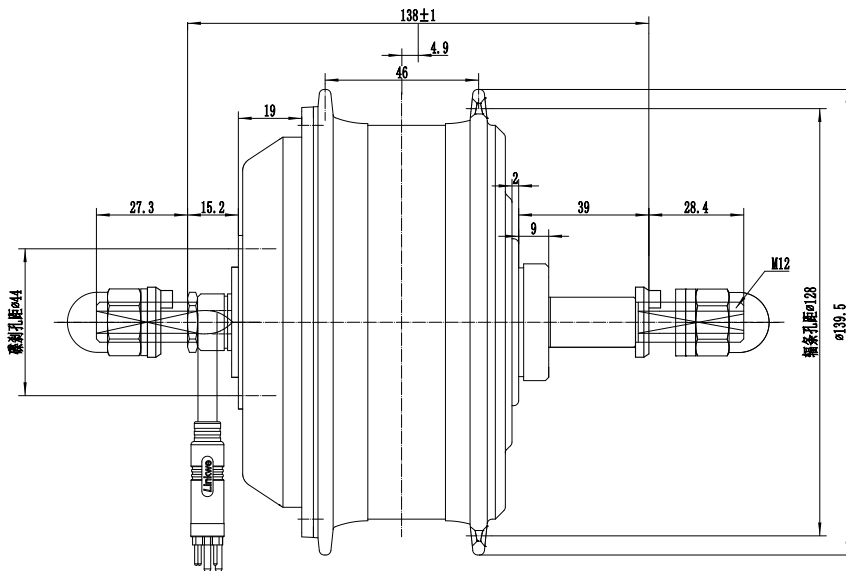

Position 安装位置	Rear	Dropout(mm)开档	138
Construction电机结构	Gear	Brake Type 刹车类型	V/Disc brake
Rated Voltage (V) 额定电压	36/48	Operating Temperature (°C) 工作温度	-20-45
Rated Power (W) 额定功率	250/350	Efficiency (%) 效率	≥82
Weight (Kg) 重量	3	Color颜色	Black/Silver
Reduction Ratio减速比	1: 5.2	Cable Location出线方式	Shaft side left
Max Torque (N.m) 最大扭矩	40	Noise Grade (dB) 噪音等级	≤55db
Wheel Diameter (Inch) 轮径	16-28	IP Grade 防水等级	IP65
Rated Speed (km/h) 额定速度	25	Salt spray Test Standard (h) 盐雾测试	24/96
Spoke Specification 辐条	36H*12G/13G	Drive and Freewheel飞轮	6-7S





# 250w cassette motor

# 90T2

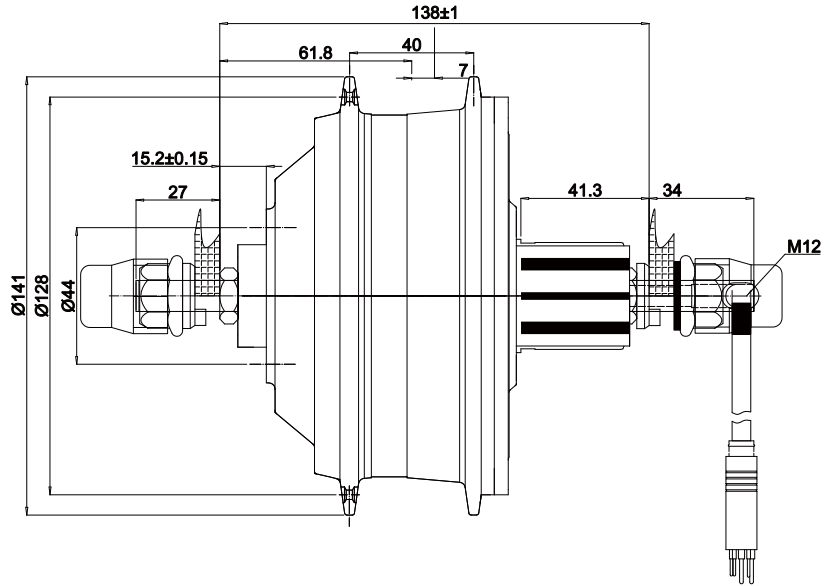

Position 安装位置	Rear	Dropout(mm)开档	138
Construction电机结构	Gear	Brake Type 刹车类型	V/Disc brake
Rated Voltage (V) 额定电压	24/36/48	Operating Temperature (°C) 工作温度	-20-45
Rated Power (W) 额定功率	180-350	Efficiency (%) 效率	≥ 82
Weight (Kg) 重量	3	Color颜色	Black/Silver
Reduction Ratio减速比	1:5.2	Cable Location出线方式	Shaft center right
Max Torque (N.m) 最大扭矩	40	Noise Grade (dB) 噪音等级	≤ 55db
Wheel Diameter (Inch) 轮径	16-28	IP Grade 防水等级	IP65
Rated Speed (km/h) 额定速度	25	Salt spray Test Standard (h) 盐雾测试	24/96
Spoke Specification辐条	36H*12G/13G	Drive and Freewheel 飞轮	9S



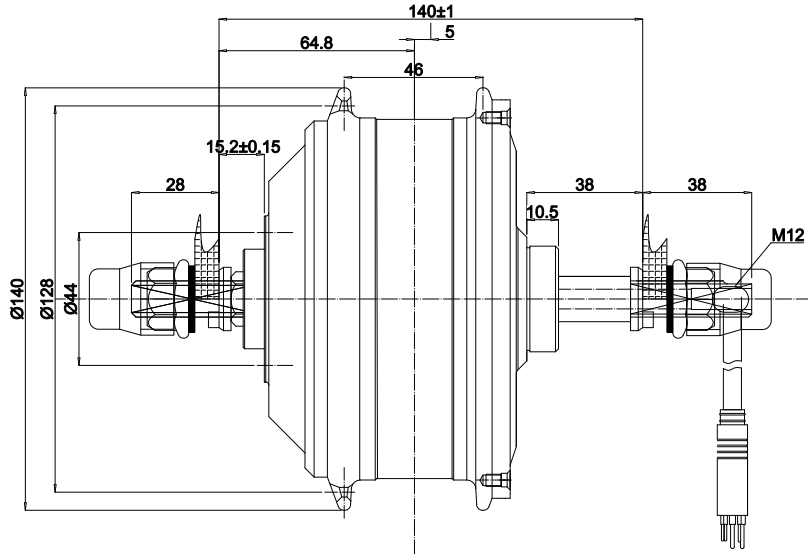

Position 安装位置	Rear	Dropout(mm)开档	140
Construction电机结构	Gear	Brake Type 刹车类型	V/Disc brake
Rated Voltage (V) 额定电压	24/36/48	Operating Temperature (°C) 工作温度	-20-45
Rated Power (W) 额定功率	180-350	Efficiency (%) 效率	≥82
Weight (Kg) 重量	3	Color颜色	Black/Silver
Reduction Ratio减速比	1:4.4	Cable Location出线方式	Shaft center right
Max Torque (N.m) 最大扭矩	35	Noise Grade (dB) 噪音等级	≤55db
Wheel Diameter (Inch) 轮径	16-28	IP Grade 防水等级	IP65
Rated Speed (km/h) 额定速度	25	Salt spray Test Standard (h) 盐雾测试	24/96
Spoke Specification辐条	36H*12G/13G	Drive and Freewheel 飞轮	6-7S







# 250w Single speed motor

# 90A3X

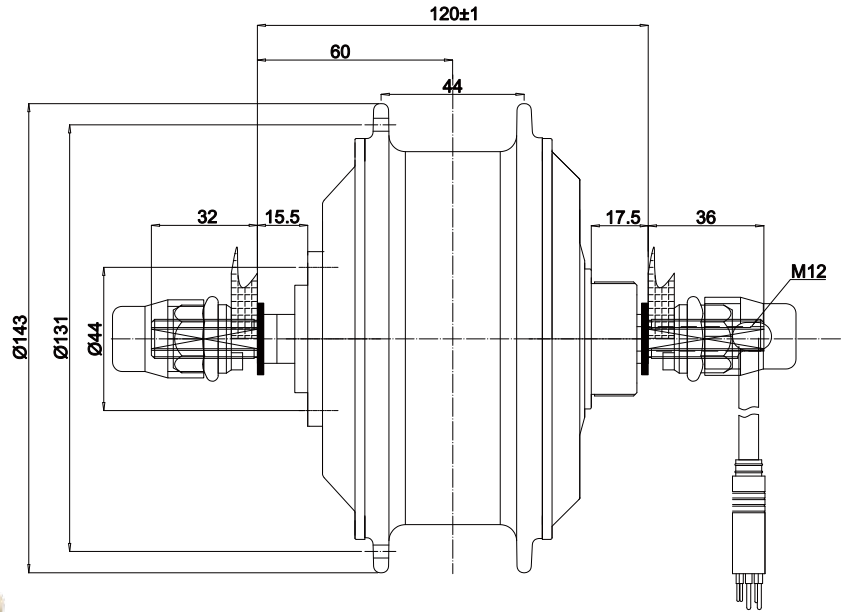

Position 安装位置	Rear	Dropout(mm)开档	125
Construction电机结构	Gear	Brake Type 刹车类型	V/Disc brake
Rated Voltage (V) 额定电压	24/36/48	Operating Temperature (°C) 工作温度	-20-45
Rated Power (W) 额定功率	180-350	Efficiency (%) 效率	≥ 82
Weight (Kg) 重量	3	Color颜色	Black/Silver
Reduction Ratio减速比	1:5.2	Cable Location出线方式	Shaft center right/side left
Max Torque (N.m) 最大扭矩	40	Noise Grade (dB) 噪音等级	≤ 55db
Wheel Diameter (Inch) 轮径	16-28	IP Grade 防水等级	IP65
Rated Speed (km/h) 额定速度	25	Salt spray Test Standard (h) 盐雾测试	24/96
Spoke Specification辐条	36H*12G/13G	Drive and Freewheel 飞轮	1S





# 350w-500w motor

# 110SZ

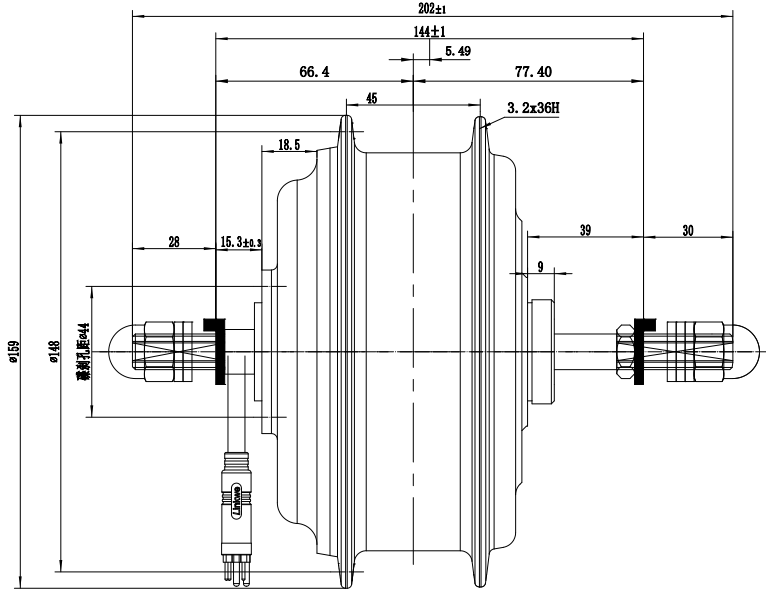

Position 安装位置	Rear	Dropout(mm)开档	144
Construction电机结构	Gear	Brake Type 刹车类型	V/Disc brake
Rated Voltage (V) 额定电压	24/36/48/60	Operating Temperature (°C) 工作温度	-20-45
Rated Power (W) 额定功率	250-500	Efficiency (%) 效率	≥82
Weight (Kg) 重量	3.5	Color颜色	Black/Silver
Reduction Ratio减速比	1:5.2	Cable Location出线方式	Shaft side left
Max Torque (N.m) 最大扭矩	55	Noise Grade (dB) 噪音等级	≤55db
Wheel Diameter (Inch) 轮径	16-28	IP Grade 防水等级	IP65
Rated Speed (km/h) 额定速度	25-42	Salt spray Test Standard (h) 盐雾测试	24/96
Spoke Specification 辐条	36H*12G/13G	Drive and Freewheel飞轮	6-7S





# 350w-500w front motor

# 105CQ

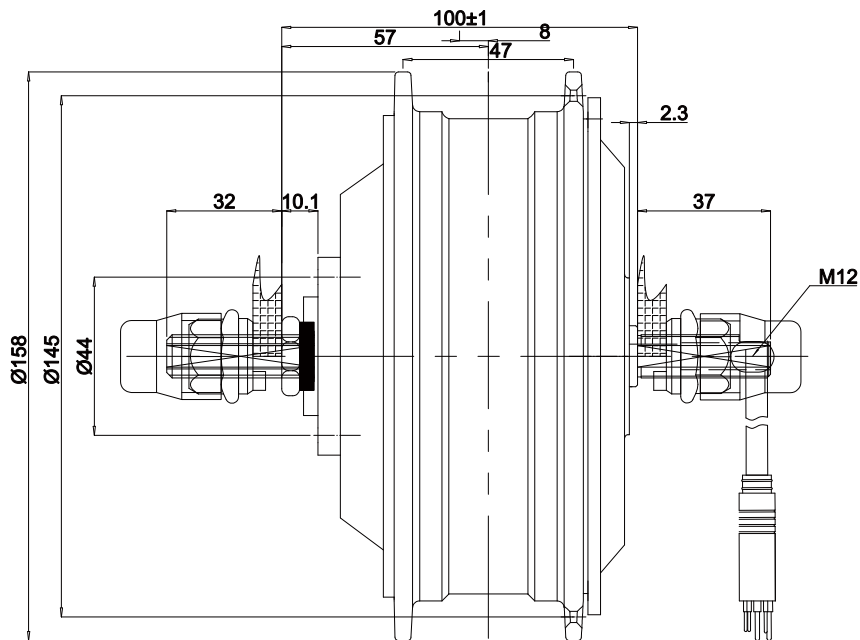

Position 安装位置	Front	Dropout(mm)开档	100
Construction电机结构	Gear	Brake Type 刹车类型	V/Disc brake
Rated Voltage (V) 额定电压	24/36/48/60	Operating Temperature (°C) 工作温度	-20-45
Rated Power (W) 额定功率	250-500	Efficiency (%) 效率	≥82
Weight (Kg) 重量	3.5	Color颜色	Black/Silver
Reduction Ratio减速比	1:5.8	Cable Location出线方式	Shaft center right
Max Torque (N.m) 最大扭矩	55	Noise Grade (dB) 噪音等级	≤55db
Wheel Diameter (Inch) 轮径	16-28	IP Grade 防水等级	IP65
Rated Speed (km/h) 额定速度	25-35	Salt spray Test Standard (h) 盐雾测试	24/96
Spoke Specification 辐条	36H*12G/13G	Drive and Freewheel飞轮	/



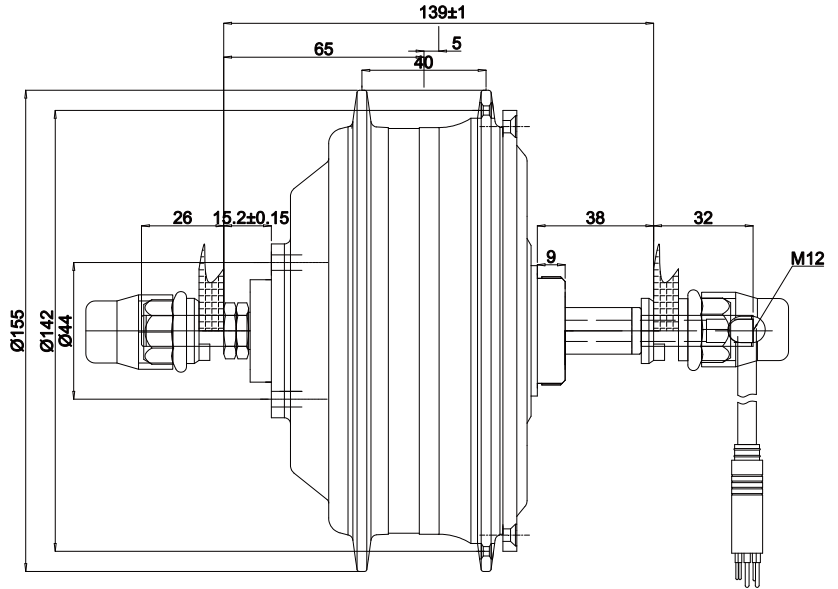

Position 安装位置	Rear	Dropout(mm)开档	139
Construction电机结构	Gear	Brake Type 刹车类型	V/Disc brake
Rated Voltage (V) 额定电压	24/36/48/60	Operating Temperature (°C) 工作温度	-20-45
Rated Power (W) 额定功率	250-500	Efficiency (%) 效率	≥82
Weight (Kg) 重量	3.5	Color颜色	Black/Silver
Reduction Ratio减速比	1:5.8	Cable Location出线方式	Shaft center right
Max Torque (N.m) 最大扭矩	55	Noise Grade (dB) 噪音等级	≤55db
Wheel Diameter (Inch) 轮径	16-28	IP Grade 防水等级	IP65
Rated Speed (km/h) 额定速度	25-35	Salt spray Test Standard (h) 盐雾测试	24/96
Spoke Specification 辐条	36H*12G/13G	Drive and Freewheel飞轮	6-7S



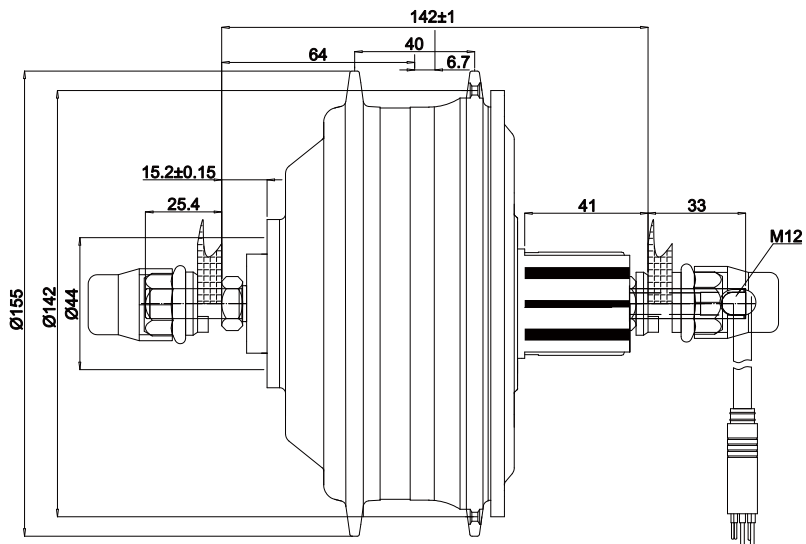

Position 安装位置	Rear	Dropout(mm)开档	142
Construction电机结构	Gear	Brake Type 刹车类型	V/Disc brake
Rated Voltage (V) 额定电压	24/36/48/60	Operating Temperature (°C) 工作温度	-20-45
Rated Power (W) 额定功率	250-500	Efficiency (%) 效率	≥82
Weight (Kg) 重量	3.5	Color颜色	Black/Silver
Reduction Ratio减速比	1: 5.8	Cable Location出线方式	Shaft center right
Max Torque (N.m) 最大扭矩	55	Noise Grade (dB) 噪音等级	≤55db
Wheel Diameter (Inch) 轮径	16-28	IP Grade 防水等级	IP65
Rated Speed (km/h) 额定速度	25-35	Salt spray Test Standard (h) 盐雾测试	24/96
Spoke Specification 辐条	36H*12G/13G	Drive and Freewheel飞轮	9S



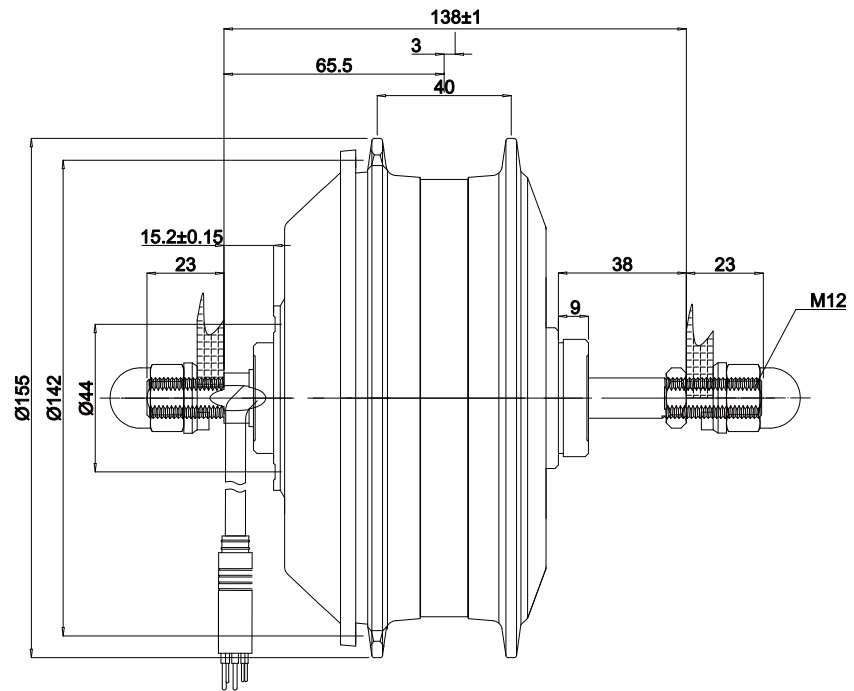

Position 安装位置	Rear	Dropout(mm)开档	138
Construction电机结构	Gear	Brake Type 刹车类型	V/Disc brake
Rated Voltage (V) 额定电压	24/36/48/60	Operating Temperature (°C) 工作温度	-20-45
Rated Power (W) 额定功率	250-500	Efficiency (%) 效率	≥82
Weight (Kg) 重量	3.5	Color颜色	Black/Silver
Reduction Ratio减速比	1:5.8	Cable Location出线方式	Shaft side left
Max Torque (N.m) 最大扭矩	55	Noise Grade (dB) 噪音等级	≤55db
Wheel Diameter (Inch) 轮径	16-28	IP Grade 防水等级	IP65
Rated Speed (km/h) 额定速度	25-35	Salt spray Test Standard (h) 盐雾测试	24/96
Spoke Specification 辐条	36H*12G/13G	Drive and Freewheel飞轮	6-7S



# 500w front motor

# 121TQ

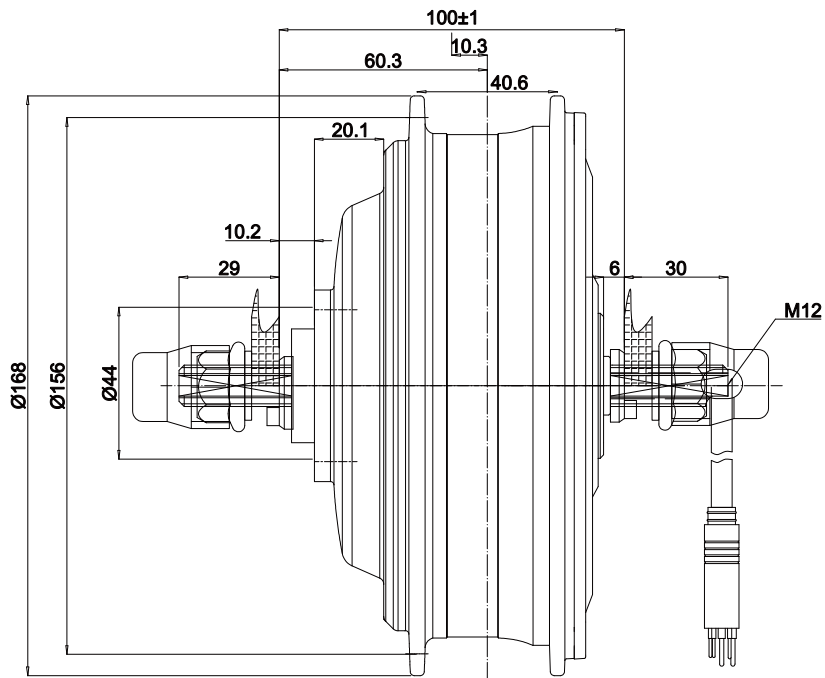

Position 安装位置	Front	Dropout(mm)开档	100
Construction电机结构	Gear	Brake Type 刹车类型	V/Disc brake
Rated Voltage (V) 额定电压	36/48	Operating Temperature (°C) 工作温度	-20-45
Rated Power (W) 额定功率	500	Efficiency (%) 效率	≥82
Weight (Kg) 重量	3.5	Color颜色	Black//Silver
Reduction Ratio减速比	1:5.2	Cabling Route出线方式	Shaft center right
Max Torque (N.m) 最大扭矩	65	Noise Grade (dB) 噪音等级	≤55db
Wheel Diameter (Inch) 轮径	16-28	IP Grade 防水等级	IP65
Rated Speed (km/h) 额定速度	25-35	Salt spray Test Standard (h) 盐雾测试	24/96
Spoke Specification 辐条	36H*12G/13G	Drive and Freewheel飞轮	/





# 500w motor

# 121T

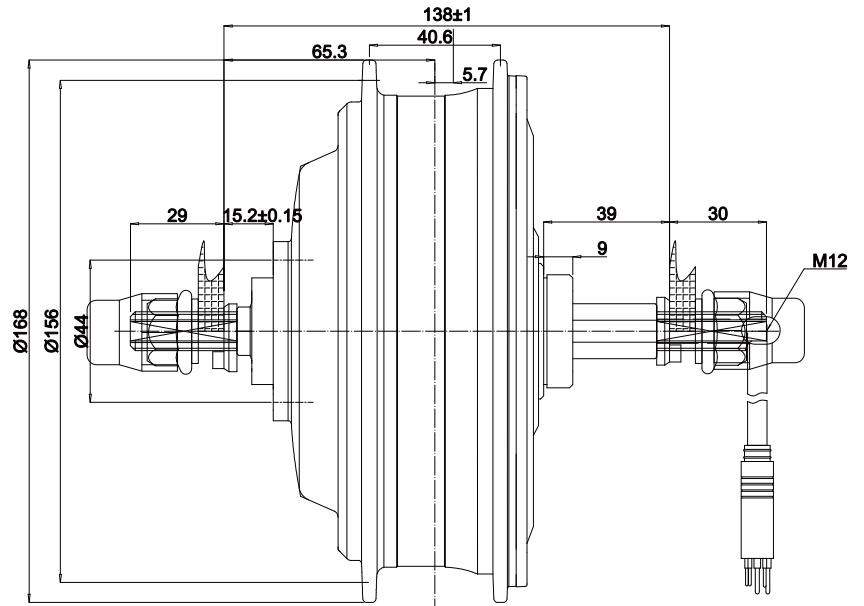

Position 安装位置	Rear	Dropout(mm)开档	138
Construction电机结构	Gear	Brake Type 刹车类型	V/Disc brake
Rated Voltage (V) 额定电压	36/48	Operating Temperature (°C) 工作温度	-20-45
Rated Power (W) 额定功率	500	Efficiency (%) 效率	≥82
Weight (Kg) 重量	3.5	Color颜色	Black/Silver
Reduction Ratio减速比	1:5.2	Cable Location出线方式	Shaft center right
Max Torque (N.m) 最大扭矩	65	Noise Grade (dB) 噪音等级	≤55db
Wheel Diameter (Inch) 轮径	16-28	IP Grade 防水等级	IP65
Rated Speed (km/h) 额定速度	25-35	Salt spray Test Standard (h) 盐雾测试	24/96
Spoke Specification 辐条	36H*12G/13G	Drive and Freewheel飞轮	6-7S







# 500w cassette motor

121T2

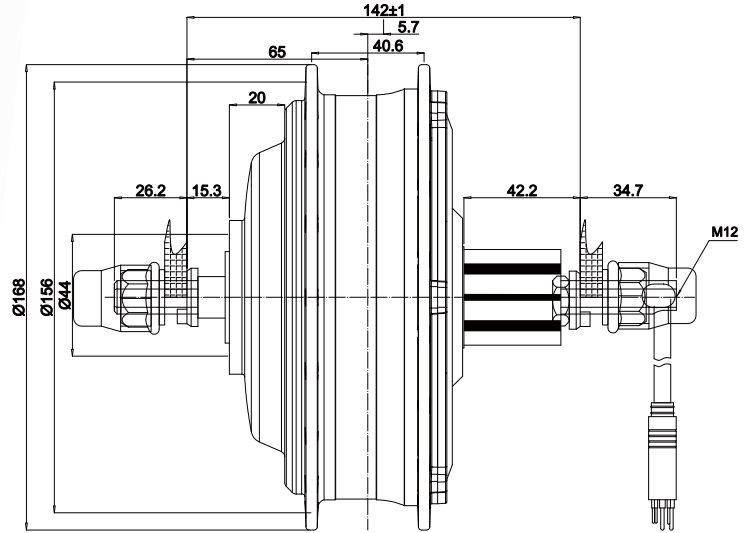

Position 安装位置	Rear	Dropout(mm)开档	142
Construction电机结构	Gear	Brake Type 刹车类型	V/Disc brake
Rated Voltage (V) 额定电压	36/48	Operating Temperature (°C) 工作温度	-20-45
Rated Power (W) 额定功率	500	Efficiency (%) 效率	≥82
Weight (Kg) 重量	3.5	Color颜色	Black/Silver
Reduction Ratio减速比	1:5.2	Cable Location出线方式	Shaft center right
Max Torque (N.m) 最大扭矩	65	Noise Grade (dB) 噪音等级	≤55db
Wheel Diameter (Inch) 轮径	16-28	IP Grade 防水等级	IP65
Rated Speed (km/h) 额定速度	25-35	Salt spray Test Standard (h) 盐雾测试	24/96
Spoke Specification 辐条	36H*12G/13G	Drive and Freewheel飞轮	9S





# 500w-750w rear motor

# 110DZ

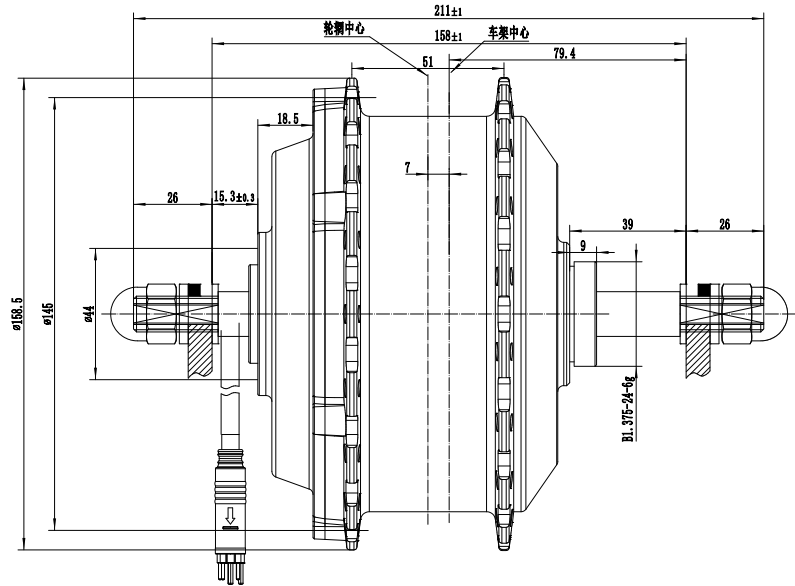

Position 安装位置	Rear	Dropout(mm)开档	158
Construction电机结构	Gear	Brake Type 刹车类型	V/Disc brake
Rated Voltage (V) 额定电压	24/36/48/60	Operating Temperature (°C) 工作温度	-20-45
Rated Power (W) 额定功率	250-750	Efficiency (%) 效率	≥82
Weight (Kg) 重量	4-4.5	Color颜色	Black/Silver
Reduction Ratio减速比	1:5.2	Cable Location出线方式	Shaft side left
Max Torque (N.m) 最大扭矩	80	Noise Grade (dB) 噪音等级	≤55db
Wheel Diameter (Inch) 轮径	16-28	IP Grade 防水等级	IP65
Rated Speed (km/h) 额定速度	25-45	Salt spray Test Standard (h) 盐雾测试	24/96
Spoke Specification 辐条	36H*12G/13G	Drive and Freewheel飞轮	6-7S





# 750w fat tire front motor

# 110CQ

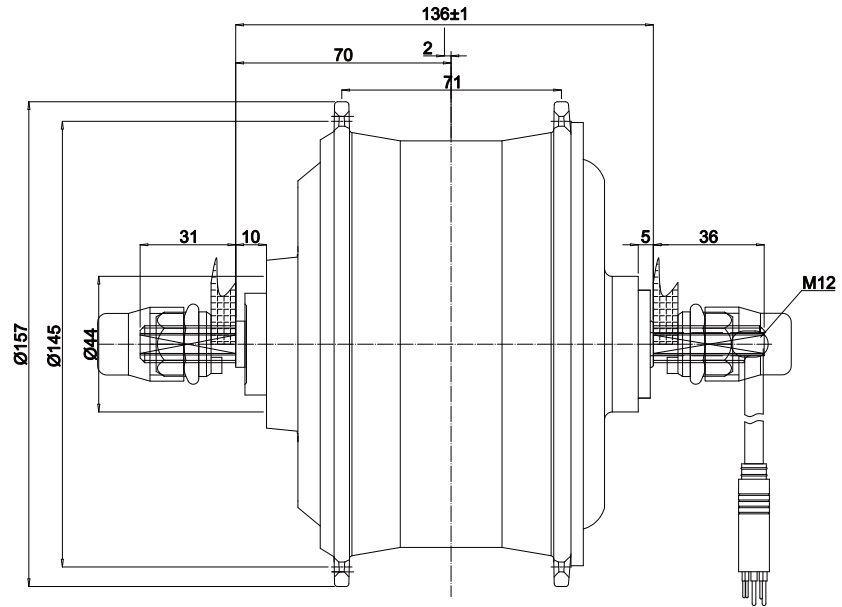

Position 安装位置	Front	Dropout(mm)开档	136
Construction电机结构	Gear	Brake Type 刹车类型	V/Disc brake
Rated Voltage (V) 额定电压	24/36/48/60	Operating Temperature (°C) 工作温度	-20-45
Rated Power (W) 额定功率	250-750	Efficiency (%) 效率	≥ 82
Weight (Kg) 重量	4.0-4.5	Color颜色	Black/Silver
Reduction Ratio减速比	350w1:5/500w1:5.2/750w1:5.8	Cable Location出线方式	Shaft center right
Max Torque (N.m) 最大扭矩	80	Noise Grade (dB) 噪音等级	≤ 55db
Wheel Diameter (Inch) 轮径	16-28	IP Grade 防水等级	IP65
Rated Speed (km/h) 额定速度	25-45	Salt spray Test Standard (h) 盐雾测试	24/96
Spoke Specification辐条	36H*12G/13G	Drive and Freewheel飞轮	6-7S





# 750w fat tire motor

# 110CS

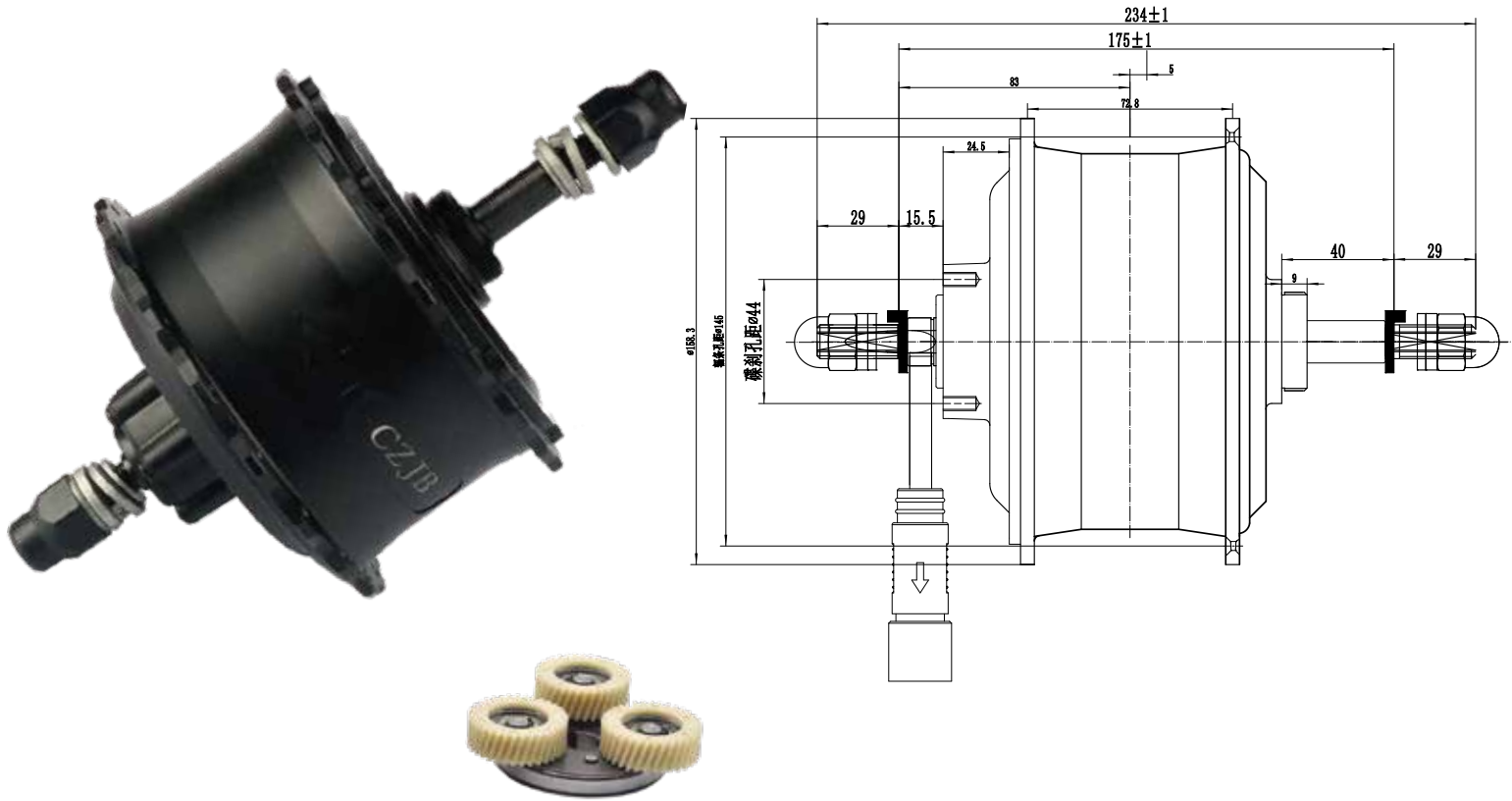

Position 安装位置	Rear	Dropout(mm)开档	170-195
Construction电机结构	Gear	Brake Type 刹车类型	V/Disc brake
Rated Voltage (V) 额定电压	36/48/60	Operating Temperature (C) 工作温度	-20-45
Rated Power (W) 额定功率	250-750	Efficiency (%) 效率	≥82
Weight (Kg) 重量	4.0-4.5	Color颜色	Black/Silver
Reduction Ratio减速比	350w1:5/500w1:5.2/750w1:5.8	Cable Location出线方式	Shaft center left/right
Max Torque (N.m) 最大扭矩	80	Noise Grade (dB) 噪音等级	≤55db
Wheel Diameter (Inch) 轮径	16-28	IP Grade 防水等级	IP65
Rated Speed (km/h) 额定速度	25-45	Salt spray Test Standard (h) 盐雾测试	24/96
Spoke Specification辐条	36H*12G/13G	Drive and Freewheel 飞轮	6-7S





# 1000w fat tire motor

# 121CZ

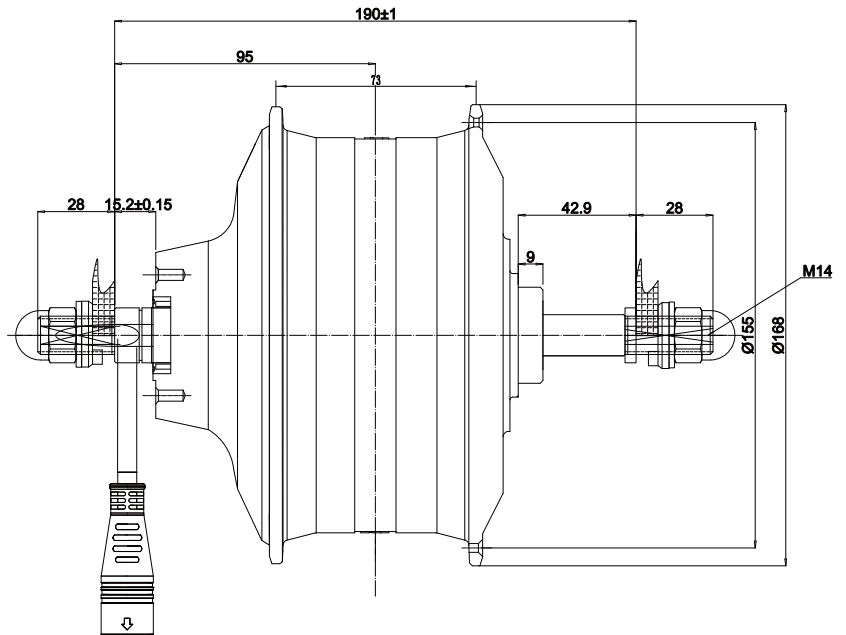

Position 安装位置	Rear	Dropout(mm)开档	175/195
Construction电机结构	Gear	Brake Type 刹车类型	V/Disc brake
Rated Voltage (V) 额定电压	36/48/60	Operating Temperature (C) 工作温度	-20-45
Rated Power (W) 额定功率	750-1000W	Efficiency (%) 效率	≥82
Weight (Kg) 重量	4.5	Color颜色	Black/Silver
Reduction Ratio减速比	350w 1:5/500w 1:5.2/750w 1: 5.8	Cable Location出线方式	Shaft center right
Max Torque (N.m) 最大扭矩	100	Noise Grade (dB) 噪音等级	≤55db
Wheel Diameter (Inch) 轮径	20-28	IP Grade 防水等级	IP65
Rated Speed (km/h) 额定速度	25-45	Salt spray Test Standard (h) 盐雾测试	24/96
Spoke Specification辐条	36H*12G/13G	Drive and Freewheel 飞轮	6-7S





# 1500w fat tire motor

# 135CZ

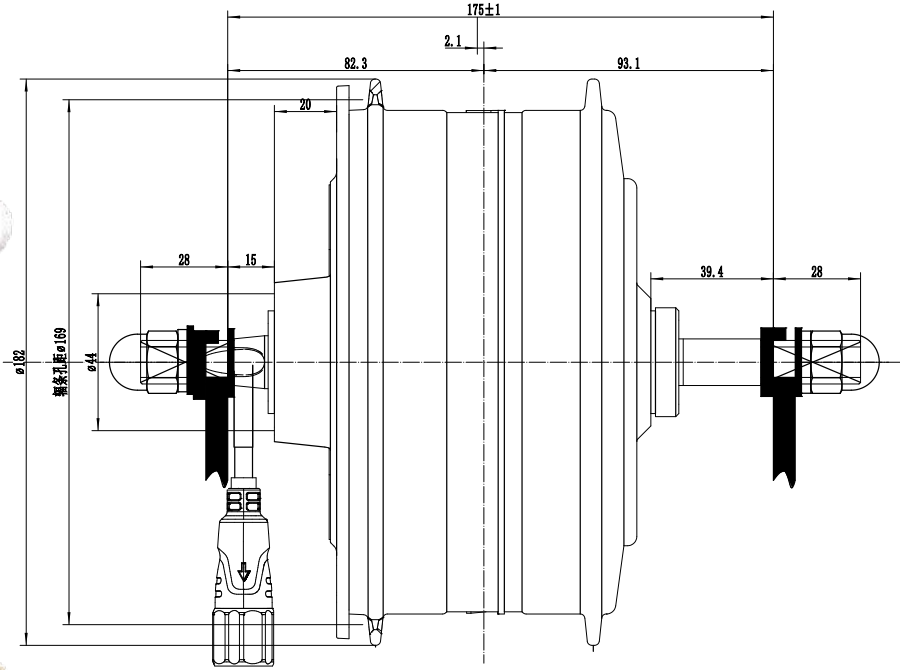

Position 安装位置	Rear	Dropout(mm)开档	175/190
Construction电机结构	Gear	Brake Type 刹车类型	V/Disc brake
Rated Voltage (V) 额定电压	48	Operating Temperature (C) 工作温度	-20-45
Rated Power (W) 额定功率	1500W	Efficiency (%) 效率	≥82
Weight (Kg) 重量	4.5	Color颜色	Black/Silver
Reduction Ratio减速比	1: 3	Cable Location出线方式	Shaft side left
Max Torque (N.m) 最大扭矩	100	Noise Grade (dB) 噪音等级	≤55db
Wheel Diameter (Inch) 轮径	20-28	IP Grade 防水等级	IP65
Rated Speed (km/h) 额定速度	65	Salt spray Test Standard (h) 盐雾测试	24/96
Spoke Specification辐条	36H*12G/13G	Drive and Freewheel 飞轮	6-7S





# 1000w motor

# 135T

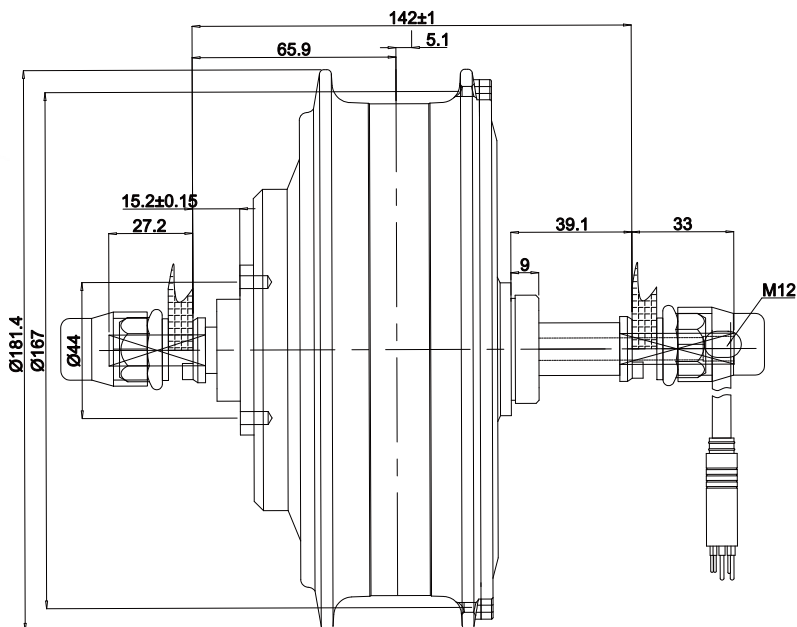

Position 安装位置	Rear	Dropout(mm)开档	141
Construction电机结构	Gear	Brake Type 刹车类型	V/Disc brake
Rated Voltage (V) 额定电压	24/36/48	Operating Temperature (°C) 工作温度	-20-45
Rated Power (W) 额定功率	800-1000	Efficiency (%) 效率	≥82
Weight (Kg) 重量	4	Color颜色	Black/Shining/Silver
Reduction Ratio减速比	1:5.8	Cable Location出线方式	Shaft center right
Max Torque (N.m) 最大扭矩	95	Noise Grade (dB) 噪音等级	≤55db
Wheel Diameter (Inch) 轮径	16-28	IP Grade 防水等级	IP65
Rated Speed (km/h) 额定速度	25-45	Salt spray Test Standard (h) 盐雾测试	24/96
Spoke Specification 辐条	36H*12G/13G	Drive and Freewheel飞轮	6-7S



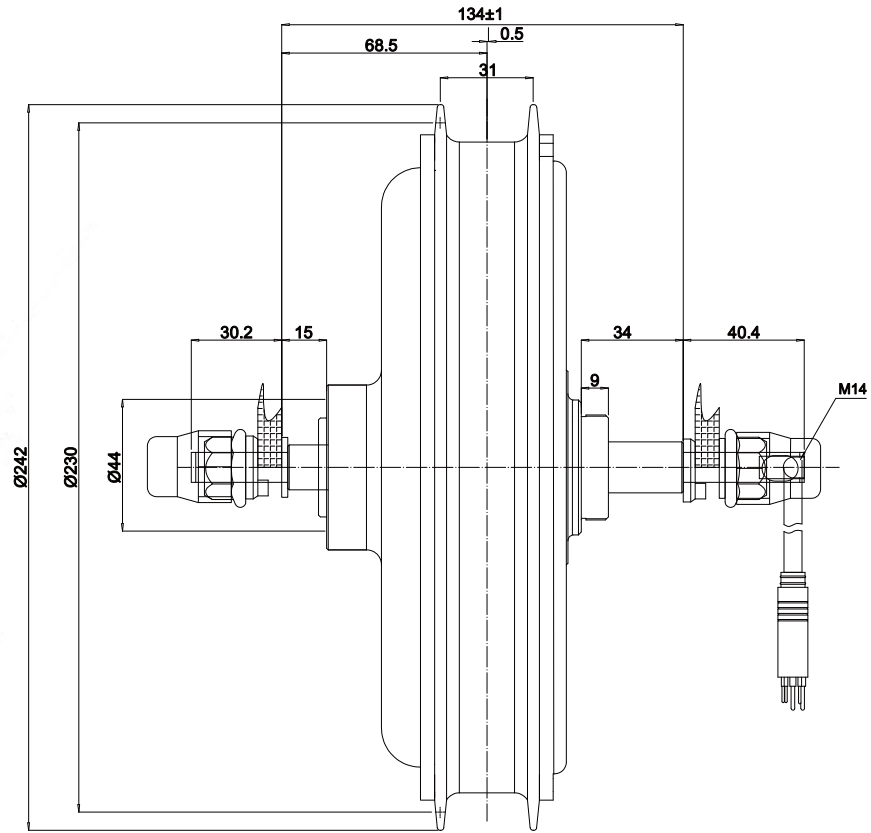

Position 安装位置	Front/Rear	Dropout(mm)开档	front:100mm rear :135
Construction电机结构	Gearless	Brake Type 刹车类型	V/Disc brake
Rated Voltage (V) 额定电压	36/48/60/72	Operating Temperature (°C) 工作温度	-20-45
Rated Power (W) 额定功率	350-1000	Efficiency (%) 效率	≥82
Weight (Kg) 重量	7	Color颜色	Black/Silver
Reduction Ratio减速比	/	Cable Location出线方式	Shaft center left/right
Max Torque (N.m) 最大扭矩	45-55	Noise Grade (dB) 噪音等级	≤55db
Wheel Diameter (Inch) 轮径	20-28	IP Grade 防水等级	IP65
Rated Speed (km/h) 额定速度	25-55	Salt spray Test Standard (h) 盐雾测试	24/96
Spoke Specification 辐条	36H*12G/13G	Drive and Freewheel飞轮	6-7S







# 1000w gearless cassette motor

## 205-35H2

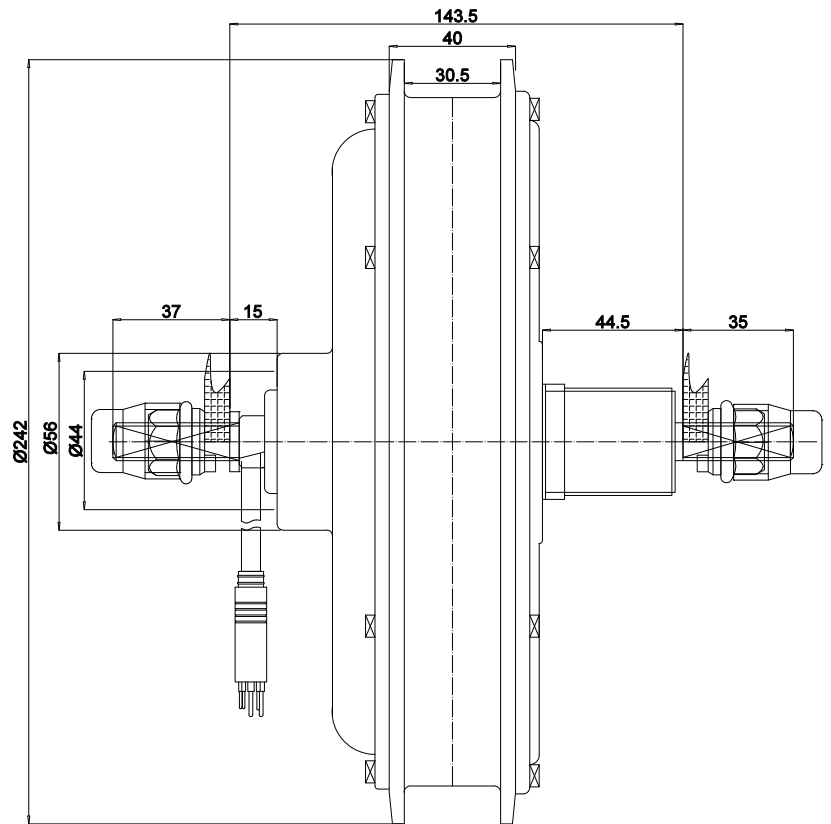

Position 安装位置	Rear	Dropout(mm)开档	140
Construction电机结构	Gearless	Brake Type 刹车类型	V/Disc brake
Rated Voltage (V) 额定电压	36/48/60/72	Operating Temperature (°C) 工作温度	-20-45
Rated Power (W) 额定功率	350-1000	Efficiency (%) 效率	≥82
Weight (Kg) 重量	7	Color颜色	Black/Silver
Reduction Ratio减速比	/	Cable Location出线方式	Shaft side left
Max Torque (N.m) 最大扭矩	45-55	Noise Grade (dB) 噪音等级	≤55db
Wheel Diameter (Inch) 轮径	20-28	IP Grade 防水等级	IP65
Rated Speed (km/h) 额定速度	25-55	Salt spray Test Standard (h) 盐雾测试	24/96
Spoke Specification 辐条	36H*12G/13G	Drive and Freewheel飞轮	9S





# 1500w-3000w gearless motor

205-55

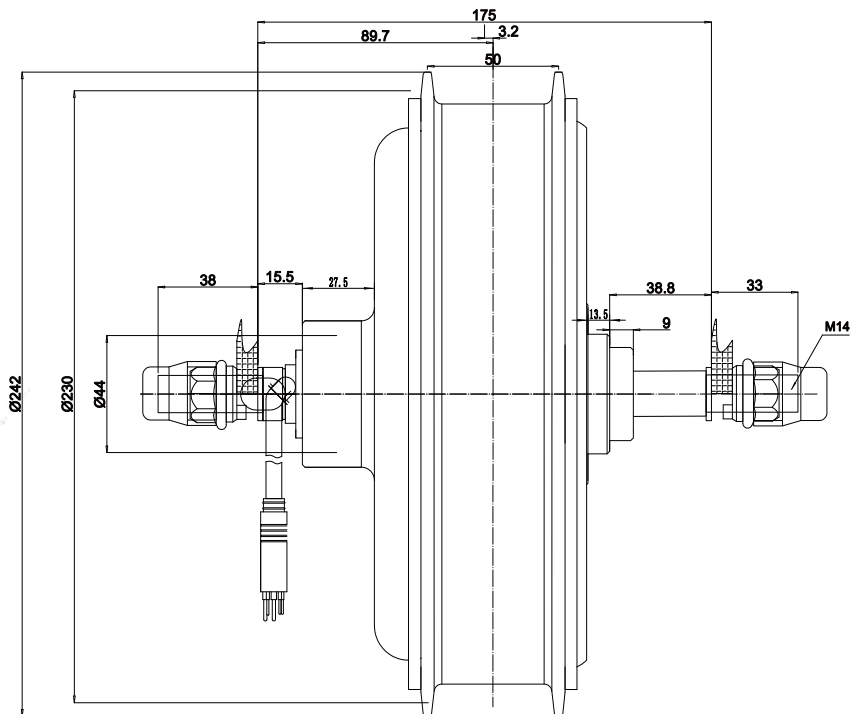

Position 安装位置	Rear	Dropout(mm)开档	175
Construction电机结构	Gearless	Brake Type 刹车类型	V/Disc brake
Rated Voltage (V) 额定电压	36/48/60/72	Operating Temperature (°C) 工作温度	-20-45
Rated Power (W) 额定功率	350-3000	Efficiency (%) 效率	≥82
Weight (Kg) 重量	7-11	Color颜色	Black/Silver
Reduction Ratio减速比	/	Cable Location出线方式	Shaft side left
Max Torque (N.m) 最大扭矩	80	Noise Grade (dB) 噪音等级	≤55db
Wheel Diameter (Inch) 轮径	20-28	IP Grade 防水等级	IP65
Rated Speed (km/h) 额定速度	25-55	Salt spray Test Standard (h) 盐雾测试	24/96
Spoke Specification 辐条	36H*12G/13G	Drive and Freewheel飞轮	6-7S





# 12" aluminium alloy motor

# 90-12"

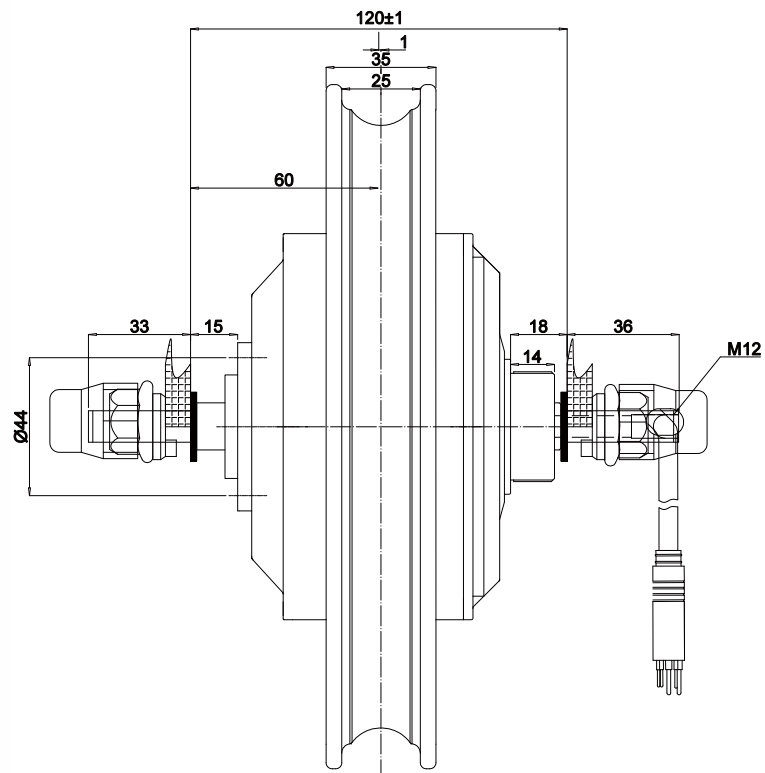

Position 安装位置	Rear	Dropout(mm)开档	120
Construction电机结构	Gear	Brake Type 刹车类型	V/Disc brake
Rated Voltage (V) 额定电压	24/36/48	Operating Temperature (°C) 工作温度	-20-45
Rated Power (W) 额定功率	180-350	Efficiency (%) 效率	≥82
Weight (Kg) 重量	3.2	Color颜色	Black/Shining/Silver
Reduction Ratio减速比	1:4.4	Cable Location出线方式	Shaft center right
Max Torque (N.m) 最大扭矩	35	Noise Grade (dB) 噪音等级	≤55db
Wheel Diameter (Inch) 轮径	12	IP Grade 防水等级	IP65
Rated Speed (km/h) 额定速度	25-30	Salt spray Test Standard (h) 盐雾测试	24/96
		Drive and Freewheel飞轮	1S





# 14" aluminium alloy motor

# 90-14"

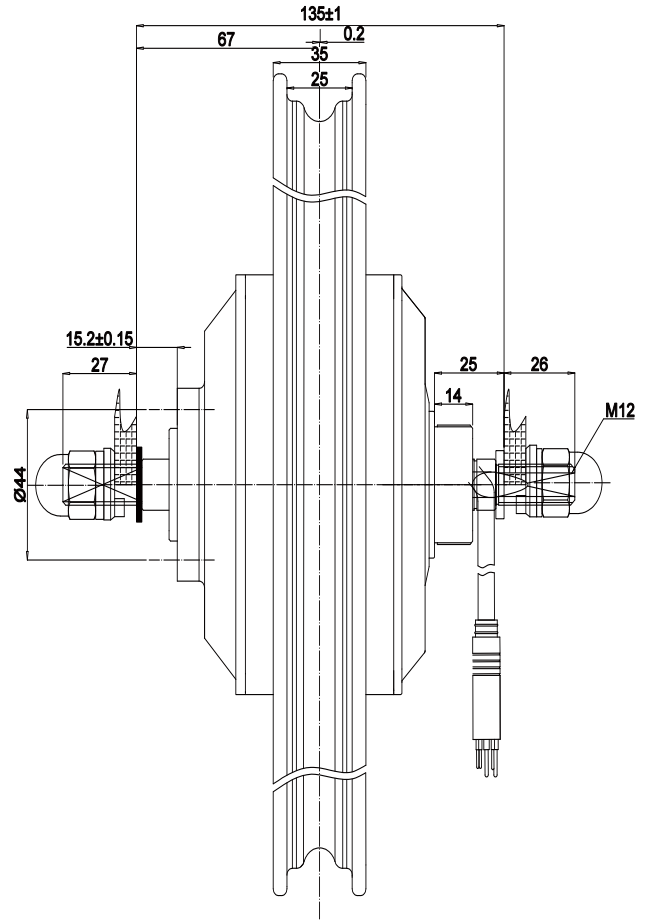

Position 安装位置	Rear	Dropout(mm)开档	135
Construction电机结构	Gear	Brake Type 刹车类型	V/Disc/Expansile brake
Rated Voltage (V) 额定电压	24/36/48	Operating Temperature (°C) 工作温度	-20-45
Rated Power (W) 额定功率	180-350	Efficiency (%) 效率	≥82
Weight (Kg) 重量	3.3	Color颜色	Black//Shining/Silver
Reduction Ratio减速比	1:4.4	Cable Location出线方式	Shaft Center Right
Max Torque (N.m) 最大扭矩	35	Noise Grade (dB) 噪音等级	≤55db
Wheel Diameter (Inch) 轮径	14	IP Grade 防水等级	IP65
Rated Speed (km/h) 额定速度	25-30	Salt spray Test Standard (h) 盐雾测试	24/96
		Drive and Freewheel飞轮	1S





# 16" aluminium/magnesium alloy motor

# 90-16"

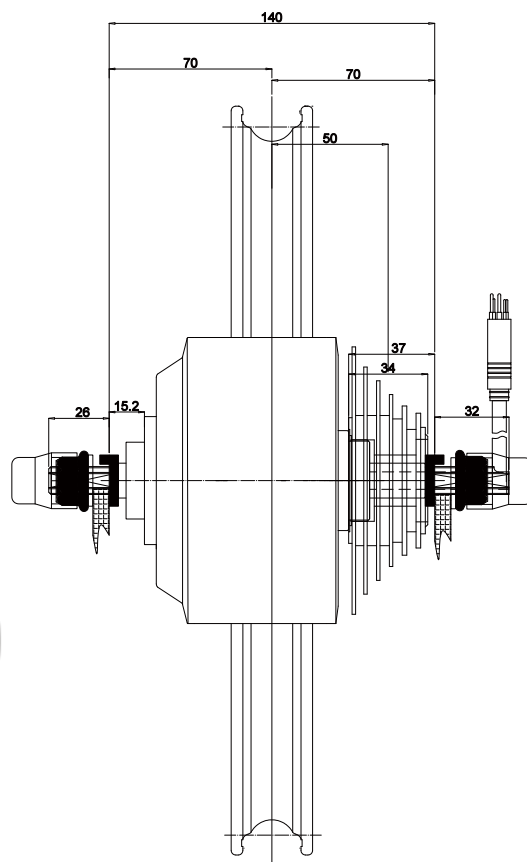

Position 安装位置	Rear	Dropout(mm)开档	135-138
Construction电机结构	Gear	Brake Type 刹车类型	V/Disc brake
Rated Voltage (V) 额定电压	36/48	Operation Temperature (°C) 工作温度	-20-45
Rated Power (W) 额定功率	250-350	Efficiency (%) 效率	≥82
Weight (Kg) 重量	3.5	Color颜色	Black/Shining/Silver
Reduction Ratio减速比	1:4.4	Cable Location 出线方式	Shaft center right
Max Torque (N.m) 最大扭矩	35	Noise Grade (dB) 噪音等级	≤55db
Wheel Diameter (Inch) 轮径	16	IP Grade 防水等级	IP65
Rated Speed (km/h) 额定速度	25	Salt spray Test Standard (h) 盐雾测试	24/96
		Drive and Freewheel飞轮	1S/7S





# 16" fat tire aluminium alloy motor

# 104-16"

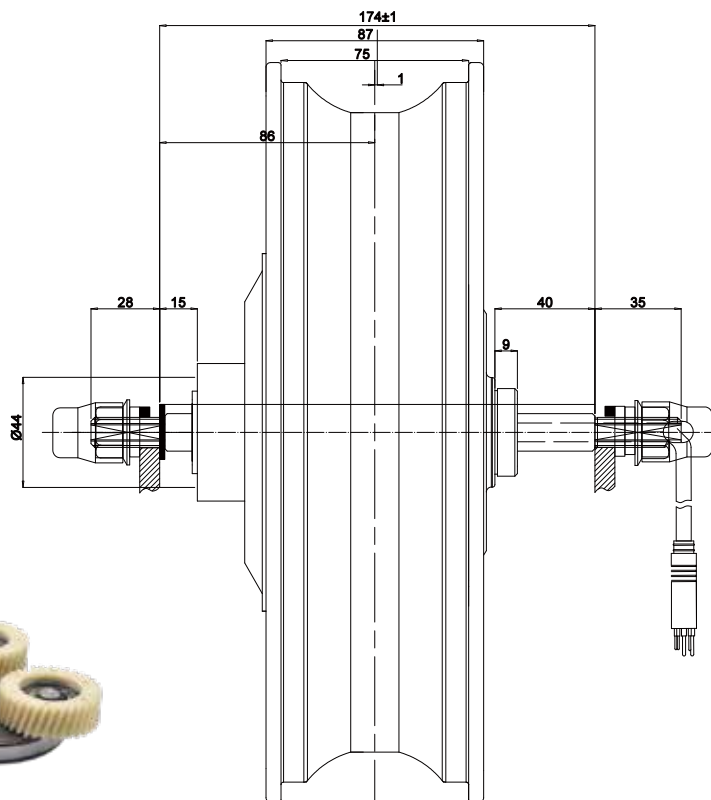

Position 安装位置	Rear	Dropout(mm)开档	175
Construction电机结构	Gear	Brake Type 刹车类型	V/Disc brake
Rated Voltage (V) 额定电压	24/36/48/60	Operation Temperature (°C) 工作温度	-20-45
Rated Power (W) 额定功率	250-750	Efficiency (%) 效率	≥82
Weight (Kg) 重量	5	Color颜色	Black//Shining/Silver
Reduction Ratio减速比	1:5.8	Cable Location 出线方式	Shaft center right
Max Torque (N.m) 最大扭矩	80	Noise Grade (dB) 噪音等级	≤55db
Wheel Diameter (Inch) 轮径	16	IP Grade 防水等级	IP65
Rated Speed (km/h) 额定速度	25-45	Salt spray Test Standard (h) 盐雾测试	24/96
		Drive and Freewheel飞轮	6-7S





# 20" aluminium/magnesium alloy motor

# 90-20"

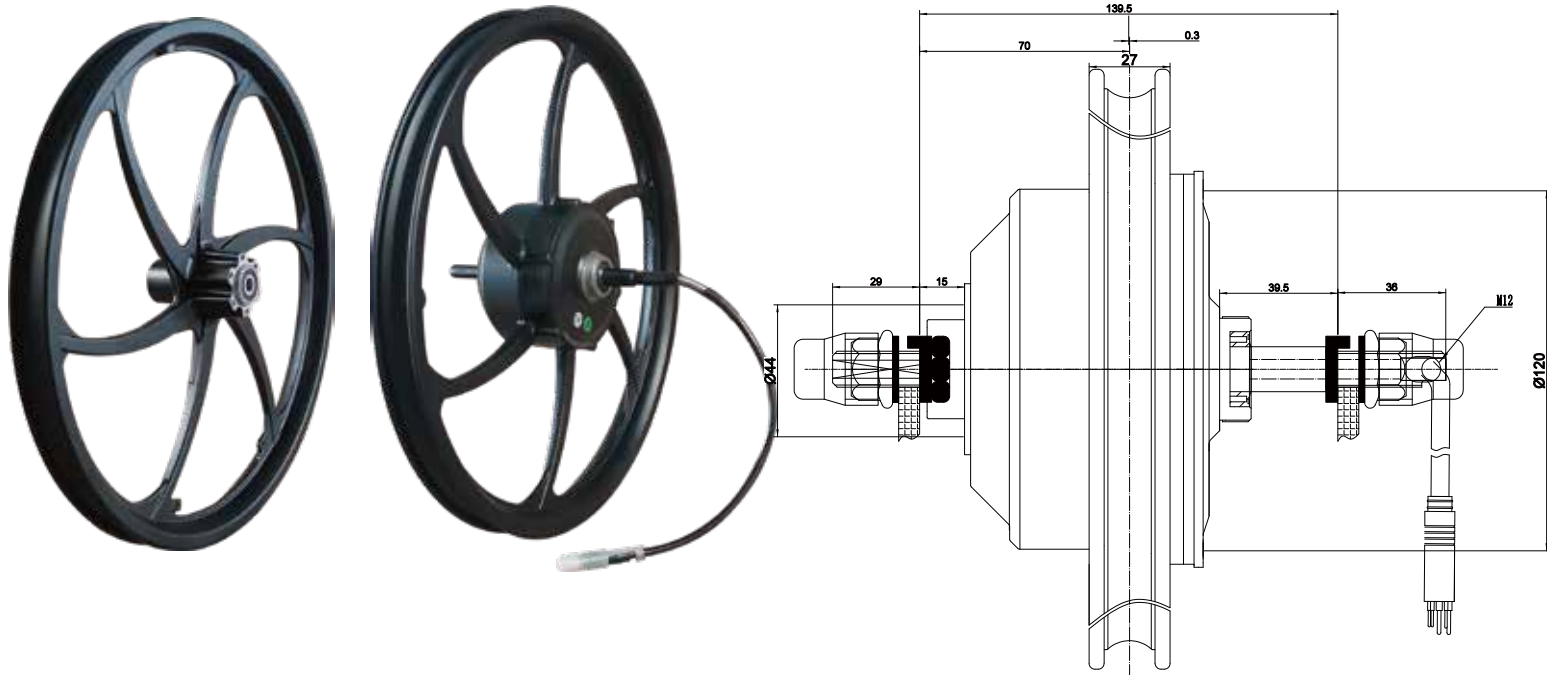

Position 安装位置	Rear	Dropout(mm)开档	140
Construction电机结构	Gear	Brake Type 刹车类型	V/Disc/Expansile brake
Rated Voltage (V) 额定电压	24/36/48	Operating Temperature (°C) 工作温度	-20-45
Rated Power (W) 额定功率	180-350	Efficiency (%) 效率	≥82
Weight (Kg) 重量	3.2	Color颜色	Black//Shining/Silver
Reduction Ratio减速比	1:4.4	Cable Location出线方式	Shaft center right
Max Torque (N.m) 最大扭矩	35	Noise Grade (dB) 噪音等级	≤55db
Wheel Diameter (Inch) 轮径	20	IP Grade 防水等级	IP65
Rated Speed (km/h) 额定速度	25-30	Salt spray Test Standard (h) 盐雾测试	24/96
		Drive and Freewheel飞轮	6-7S





# 20" fat tire aluminium alloy motor

# 104-20"

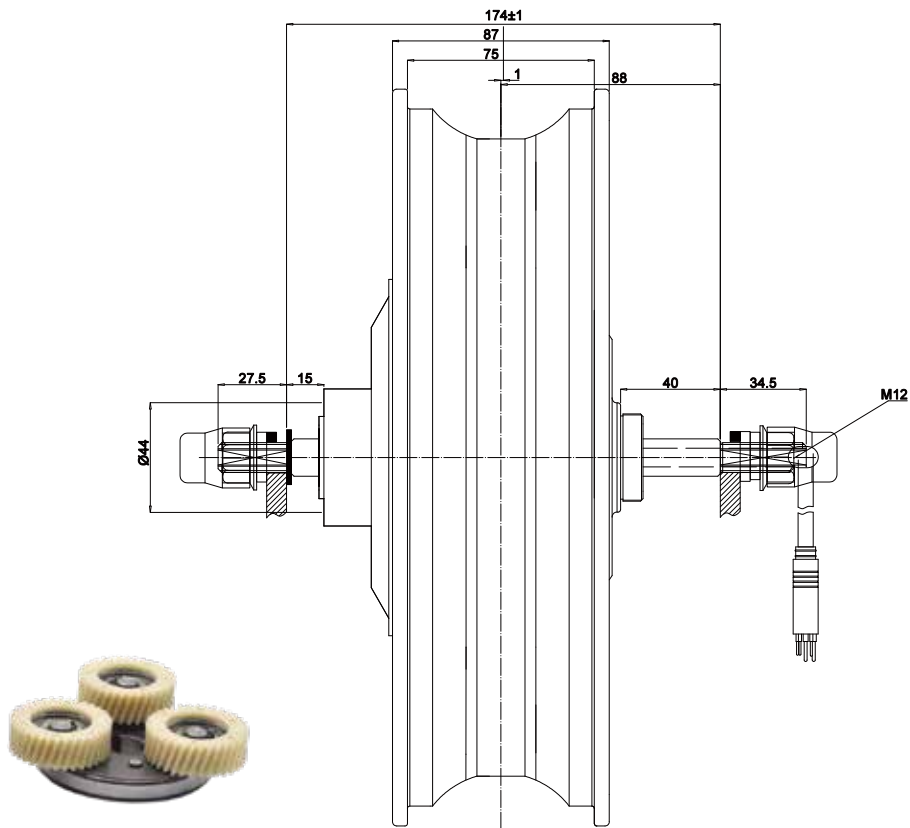

Position 安装位置	Rear	Dropout(mm)开档	175
Construction电机结构	Gear	Brake Type 刹车类型	V/Disc brake
Rated Voltage (V) 额定电压	24/36/48/60	Operation Temperature (°C) 工作温度	-20-45
Rated Power (W) 额定功率	250-750	Efficiency (%) 效率	≥82
Weight (Kg) 重量	6	Color颜色	Black//Shining/Silver
Reduction Ratio减速比	1:5.8	Cable Location出线方式	Shaft center right
Max Torque (N.m) 最大扭矩	80	Noise Grade (dB) 噪音等级	≤55db
Wheel Diameter (Inch) 轮径	20	IP Grade 防水等级	IP65
Rated Speed (km/h) 额定速度	25-45	Salt spray Test Standard (h) 盐雾测试	24/96
		Drive and Freewheel飞轮	6-7S







## E-bike customized Kit



350W-500W E-bike system  
E-MID



250W Torque sensor system  
E-CITY



250W-1000W E-bike system  
E-CITY E-ROAD E-MTB



250W-1500W E-bike system  
E-FAT

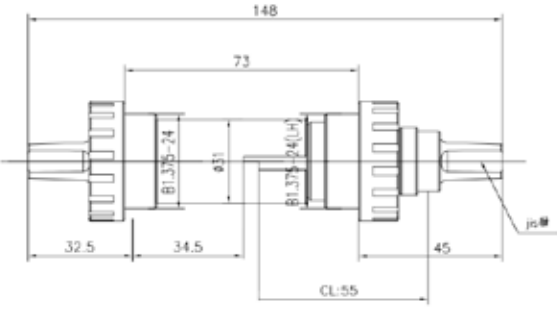

## Torque Sensor

image 图片	
size 尺寸	
model 型号	JBHT-01
Power supply voltage 供电电压	4.5-5.5 VDC
Measuring torque signal range 测量力矩信号量程	0.5~80N.m
Number of output speed signal pulses 输出速度信号脉冲数	36
Output direction signal 输出方向信号	前进:3.1VDC 后退:0VDC
Output torque signal voltage 输出力矩信号电压	0.75~3.1 VDC
Output torque resolution 输出力矩分辨率	35mV/N.m
Protection level 防护等级	IP65
Measurement accuracy 测量精度	3%
Working temperature 工作温度	(-20~+60) ° C
Storage temperature 保存温度	(-20~+60) ° C

*New products or other products, please check our website  
and contact our sales.*



## EBIKE REPAIR STAND 全自动修车架



Rated Voltage 额定电压	110V
Jaw Height 钳口高度	70mm
Clamp capacity 加持能力	Round pipes and aviation pipes with widths ranging from 30mm (1.18 inches) to 72mm (2.84 inches) 宽度为 30mm(1.18inch)至 72mm(2.84inch)的圆形管和航空管
Clamp height 夹具高度	The height can be adjusted within a range of 32 可通过电动马达在32 厘米(16inch)至 210厘米(82.67inch)范围内调节
Total height 带底座和附件杆的全高	22458mm/96.77inch
Max load for single 最大承重	Single 单边65kg/143lbs
Total weight 总重	94kg/205lbs